

YASKAWA

YASKAWA AC Drive Compact Vector Control Drive V1000

200 V CLASS, THREE-PHASE INPUT: 0.1 to 18.5 kW
200 V CLASS, SINGLE-PHASE INPUT: 0.1 to 3.7 kW
400 V CLASS, THREE-PHASE INPUT: 0.2 to 18.5 kW



So advanced !

So easy !

So small !



Bringing you the world's smallest* variable speed drive to stand at the top of its class: V1000

Yaskawa has built a reputation for high performance, functionality, quality, and reliability. To make it even easier to optimize your applications, we present the new V1000.

A single drive with so many uses, benefiting your application the more you use it.

So advanced!

*: Results from market research on vector drives performed by Yaskawa.

Quick and easy installation, ready to run your application in no time. You'll be amazed how simple it is to use.

So easy!

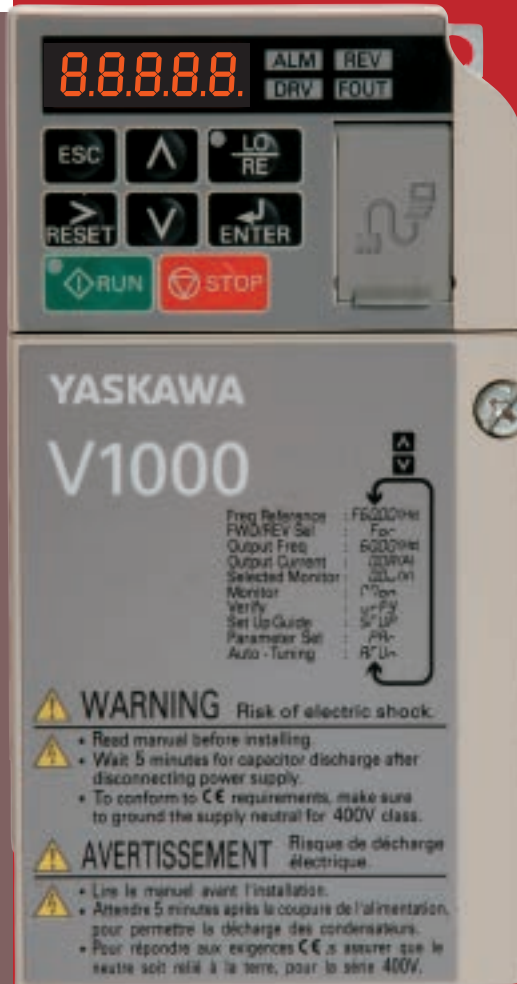

Smallest in the world!

Top performance for its class. Loaded with functions and features in an unbelievably small package!



C O N T E N T S

Features	4	
Application Benefits	8	
Software Functions	10	
Parameter List	12	
Basic Instructions	16	
Product Lineup	18	
Model Selection	19	
Standard Specifications	20	
Standard Connection Diagram	22	
Dimensions	24	
Fully-Enclosed Design and Watt Loss Data	26	
Peripheral Devices and Options	28	
Application Notes	50	
YASKAWA AC Drive Series	57	
Warranty	58	
Global Service Network	59	



PUMP



FAN

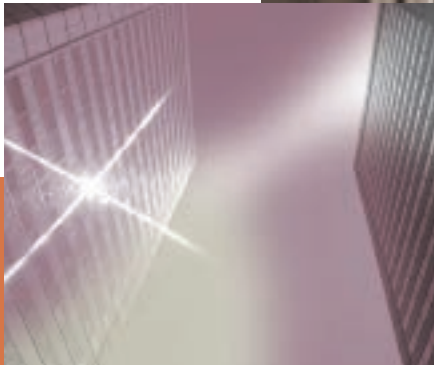

HVAC

FLUID MACHINE ▶ See page 8.

APPLICATIONS

COMPACT CONVEYOR ▶ See page 9.

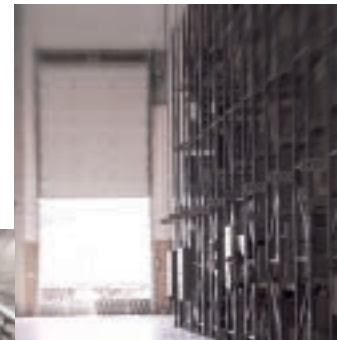

AUTO SHUTTER



PACKAGING



CONVEYOR

Even more eye-opening versatility.

V1000

Features

Yaskawa offers solutions customized for your application in an incredibly compact, technologically advanced, environmentally responsible package capable of driving a synchronous motor.

So advanced!

Sensorless Control of PM Motors Capability

Two drives in one

V1000 runs not only induction motors, but synchronous motors like IPM and SPM motors as well. Get a single drive for all your application needs, and save on spare parts.

Note: See product specifications for information on motor precision.
The variable torque ratio of synchronous motors is 1 to 10.

Conventional models

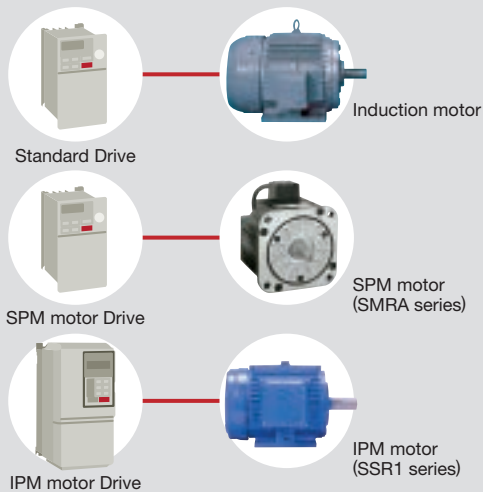

V1000

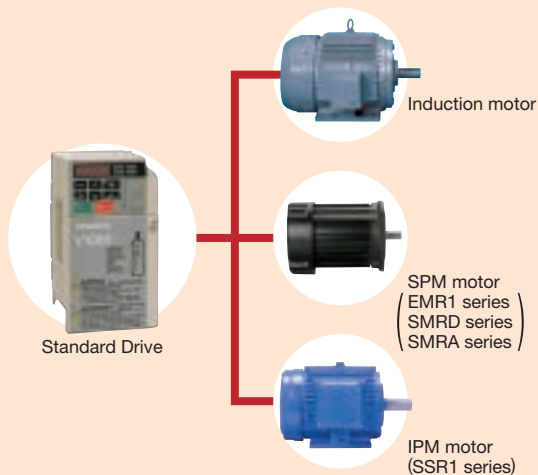

Top of Its Class

Impressive Torque Characteristics

V1000 is the first in its class fully equipped with current vector control. Current Vector control providing a powerful starting torque of 200% at 0.5 Hz* and precise torque limit operations. The motor Auto-Tuning function saves valuable start up time and assures high performance operation at the highest efficiency.

*: Using a Yaskawa induction motor under 3.7 kW set for Heavy Duty torque performance.

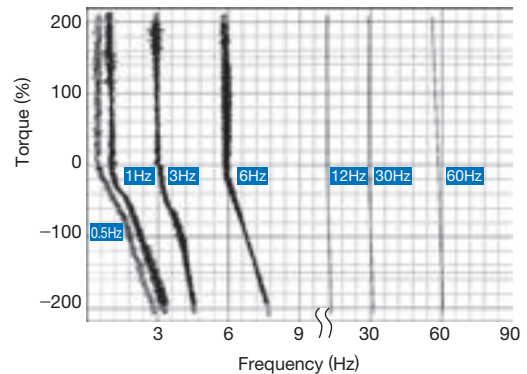

Increased braking power during deceleration.

Faster deceleration time with overexcitation braking.*

*: Example shown is for a 400 V 3.7 kW drive without braking resistor. Circumstances depends on the motor and load.

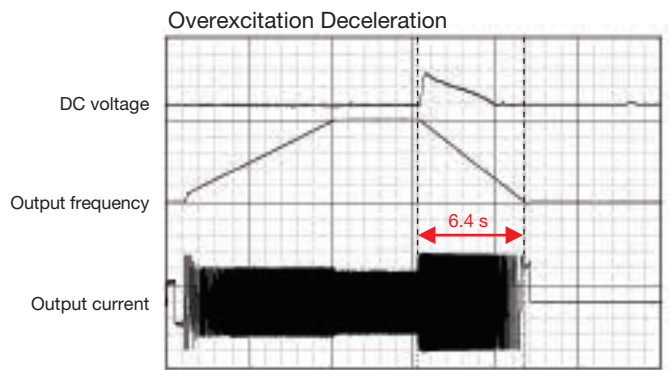
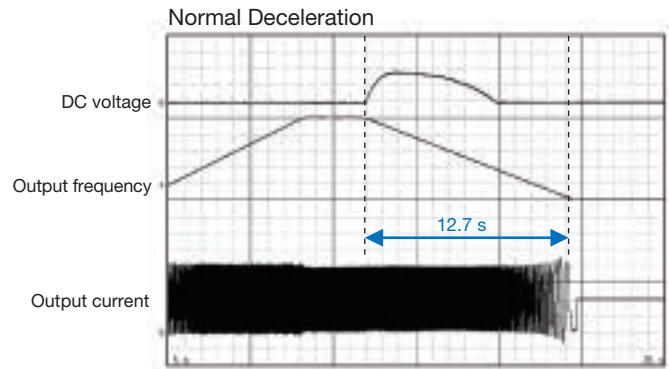

50% faster!

simplest, smallest drive of its class.

No more trouble from power loss.

V1000 is fully equipped with speed search and KEB Ride-Thru functions for your application needs, whether running an induction motor or permanent magnet motor.

● Speed Search Method

Easily restart the motor without cumbersome speed sensors. Perfect for fan, blowers, and other rotating, fluid-type applications.

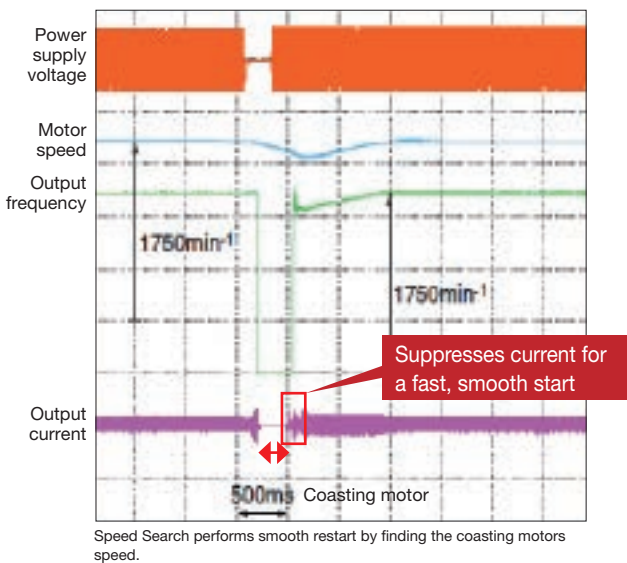

● KEB Ride-Thru

Drive continues operation by using motor regen. Perfect for HVAC

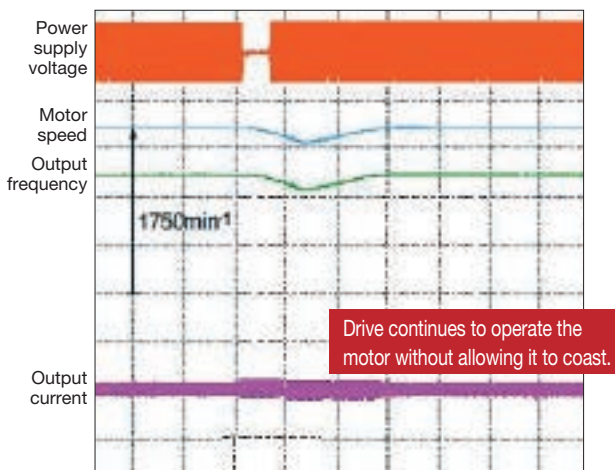

Note: Requires a sensor to detect when power loss occurs. Load conditions may still trip a fault and cause the motor to coast.

Drive Specialization

Software for High-Frequency Output

Yaskawa can offer you a drive with custom software with the specific functions required for your machine.

Customize the Drive

Optional visual programming software lets you instantly customize V1000 to your application. Let the drive do external device or PLC functions! Easy Drag and Drop functions starting from simple timers up to complex application blocks let you create your very own drive.



So much variation possible

Global Networking

The built in high speed RS-422/485 MEMOBUS/Modbus (RTU mode) Communications and a variety of option units connect V1000 to all popular fieldbus networks. The optional 24 V power supply keeps the drive controller alive under all conditions, providing network communications and monitoring functions even during a main power loss.

Open Field Network	MECHATROLINK-II	MECHATROLINK-III*
	CC-Link	
	DeviceNet	
	CompoNet	
	PROFIBUS-DP	
	CANopen	
	EtherCAT	
	EtherNet/IP	
	Modbus/TCP	
	PROFINET	

*: Available in drive software versions PRG: S1023 and later. Contact Yaskawa for more information.

Note: The open field network names mentioned are registered trademarks of their respective companies.

Specialized Types

Finless design, and dust-proof, water-proof type models also available.

Dust-proof, water-proof type >>> NEMA4X/IP66



<<< Fin-less



Environmentally Friendly

Protecting Against Harsh Environments

Various products are available to protect your drive against humidity, dust, oil mist, and vibration. Contact Yaskawa for more information.

EU's RoHS Compliance

All V1000 models are fully compliant with the EU's RoHS initiative.

Features

From setup to maintenance, V1000 makes life easy.

So easy!

Parameters set automatically—hassle free programming!

Start up instantly with application presets!

V1000 automatically sets the parameters needed for various applications. Presets for water supply pumps, conveyor systems, exhaust fans, and other applications program the drive instantly for optimized performance—saving enormous hassle setting up for a test run.

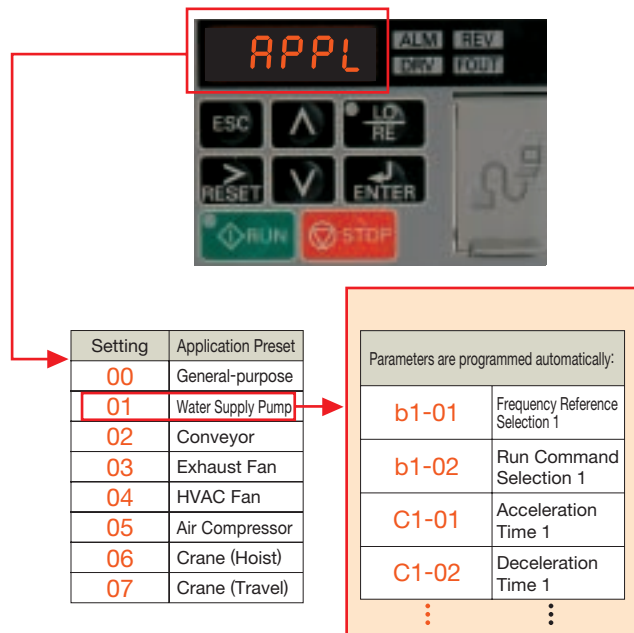

Setting	Application Preset
00	General-purpose
01	Water Supply Pump
02	Conveyor
03	Exhaust Fan
04	HVAC Fan
05	Air Compressor
06	Crane (Hoist)
07	Crane (Travel)

Parameters are programmed automatically:	
b1-01	Frequency Reference Selection 1
b1-02	Run Command Selection 1
C1-01	Acceleration Time 1
C1-02	Deceleration Time 1
⋮	⋮

Breeze-Easy Setup

Install Multiple Drive Immediately with the USB Copy Unit

Get several drives up and running easily using the USB copy unit. The same copy unit is fully PC compatible.

Hassle free setting and maintenance straight from a PC

DriveWizard Plus lets you manage the unique settings for all your drives right on your PC.

With DriveWizard's preset operation sequences, built-in oscilloscope function, fine tuning the drive and maintenance checks have never been easier.

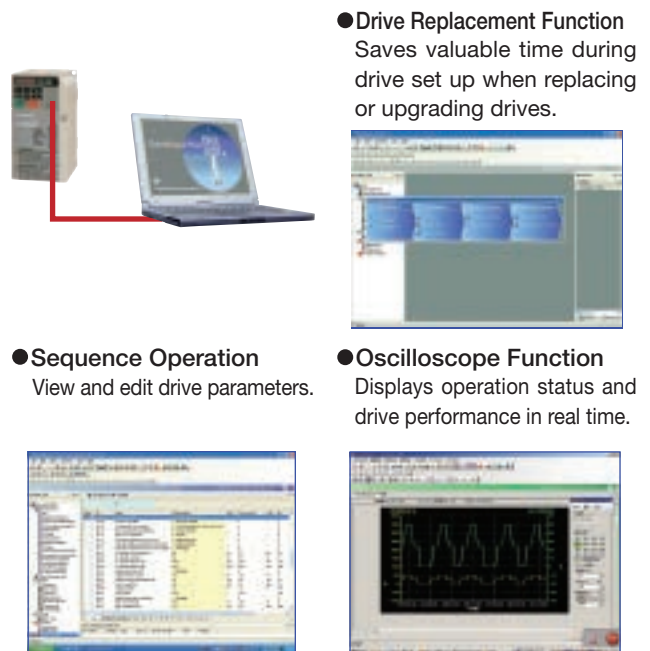

- Drive Replacement Function**
 Saves valuable time during drive set up when replacing or upgrading drives.
- Sequence Operation**
 View and edit drive parameters.
- Oscilloscope Function**
 Displays operation status and drive performance in real time.

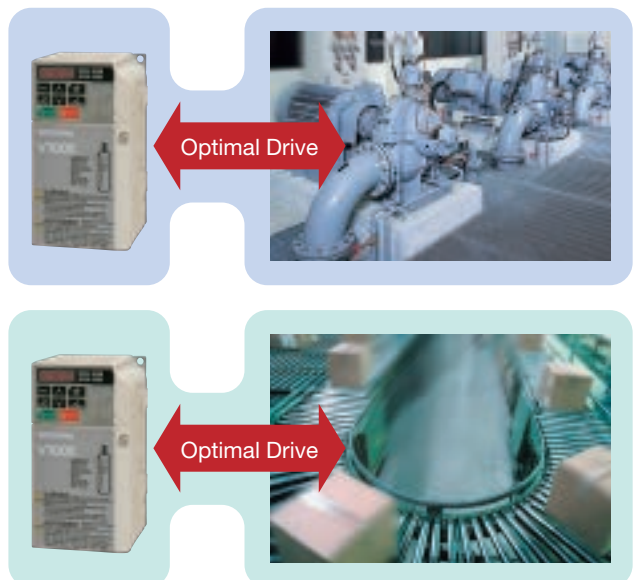

Optimal Drive

Optimal Drive

Safety Standard Compliance TÜV approved

V1000 is the first drive in its class to come standard with safety input features compliant with ISO/EN13849-1 Cat.3 PLd, IEC/EN61508 SIL2.

Through compliance with EN60204-1 (stop category 0), V1000 reduces the number of peripheral devices needed to satisfy safety regulations.

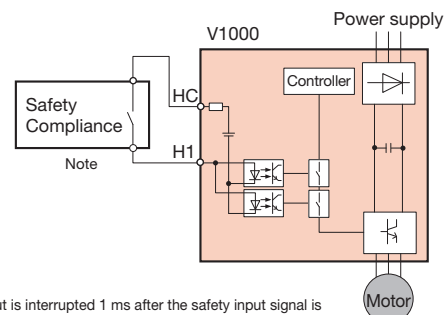

Note: Output is interrupted 1 ms after the safety input signal is triggered.
 Make sure safety input wiring does not exceed 30 m.

Application Example: Safety Compliance

Hassle-Free Maintenance

Less Downtime

The first-ever pluggable terminal board with a Parameter Back-Up function lets you replace a drive instantly in the event of failure. No need to re-program the replacement drive—an amazingly convenient time saver!

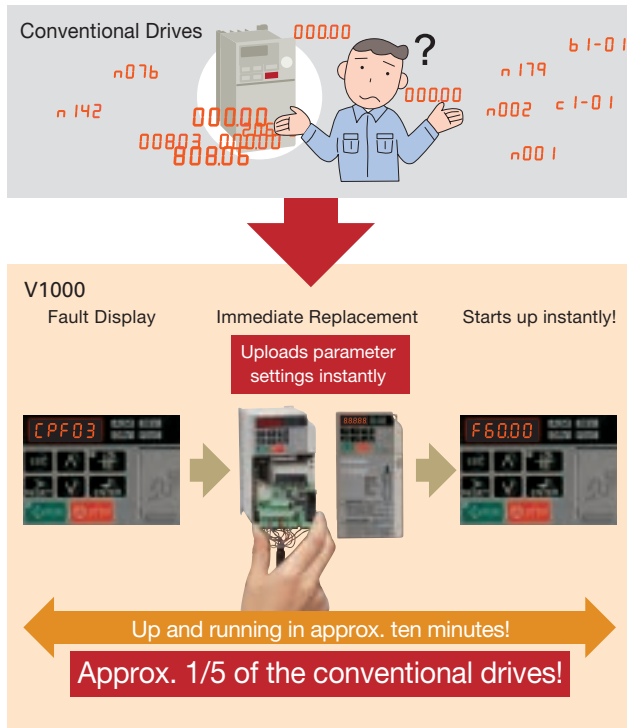

Exceptional Performance Life

Cooling fan and capacitors have an expected performance life of ten years. In addition, Maintenance Monitors keep track of part wear.

Note: Assumes the drive is running continuously for 24 hours a day at 80% load with an ambient temperature of 40°C with an IP20 open-chassis enclosure.

Simple Wiring

A pluggable terminal block option is available. Screwless terminals do away with time consuming wiring and periodic maintenance to check wire connections, which in turn makes the drive more reliable. Contact Yaskawa for inquiries.

Wide Array of Monitors

Monitor functions like output frequency, output current, I/O status and watt hour counter give a clear picture of the drive operation status and helps to keep track of the energy consumption.

Verify Menu

The Verify Menu lists all setting that have been changed from their original default values. This includes parameters changed by Auto-Tuning, Application Presets, and those edited by the technician. This list makes it easy to reference changes to drive setup.

The world's smallest!

The perfect space-saving design

World's Smallest Class

Yaskawa has applied the most advanced thermal simulation technology and top reliability to create the world's smallest compact drive. V1000 reduces the space required up to 70% when compared to our earlier models.

● Compare the size difference of a 200 V 5.5 kW drive with V1000 rated for Normal Duty operation:

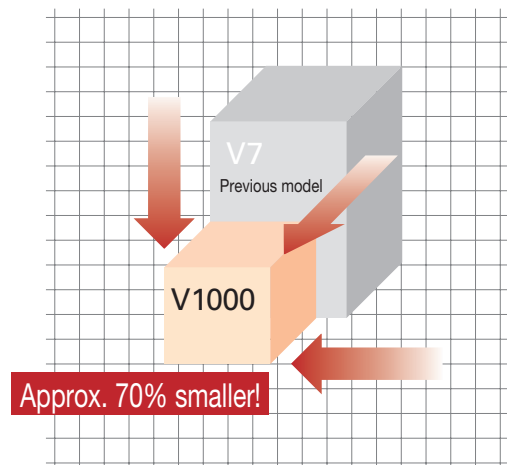

Side-by-Side

V1000 allows for a truly compact installation, requiring minimal space between units even in a tight enclosure.

Note: Current derating must be considered.

● Example: Side-by-Side installation of 200 V 0.75 kW units

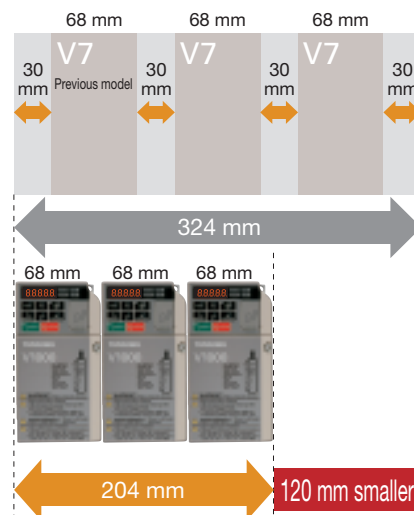

Note: If the last drive in a series is installed next to a wall, a 30 mm gap is required.

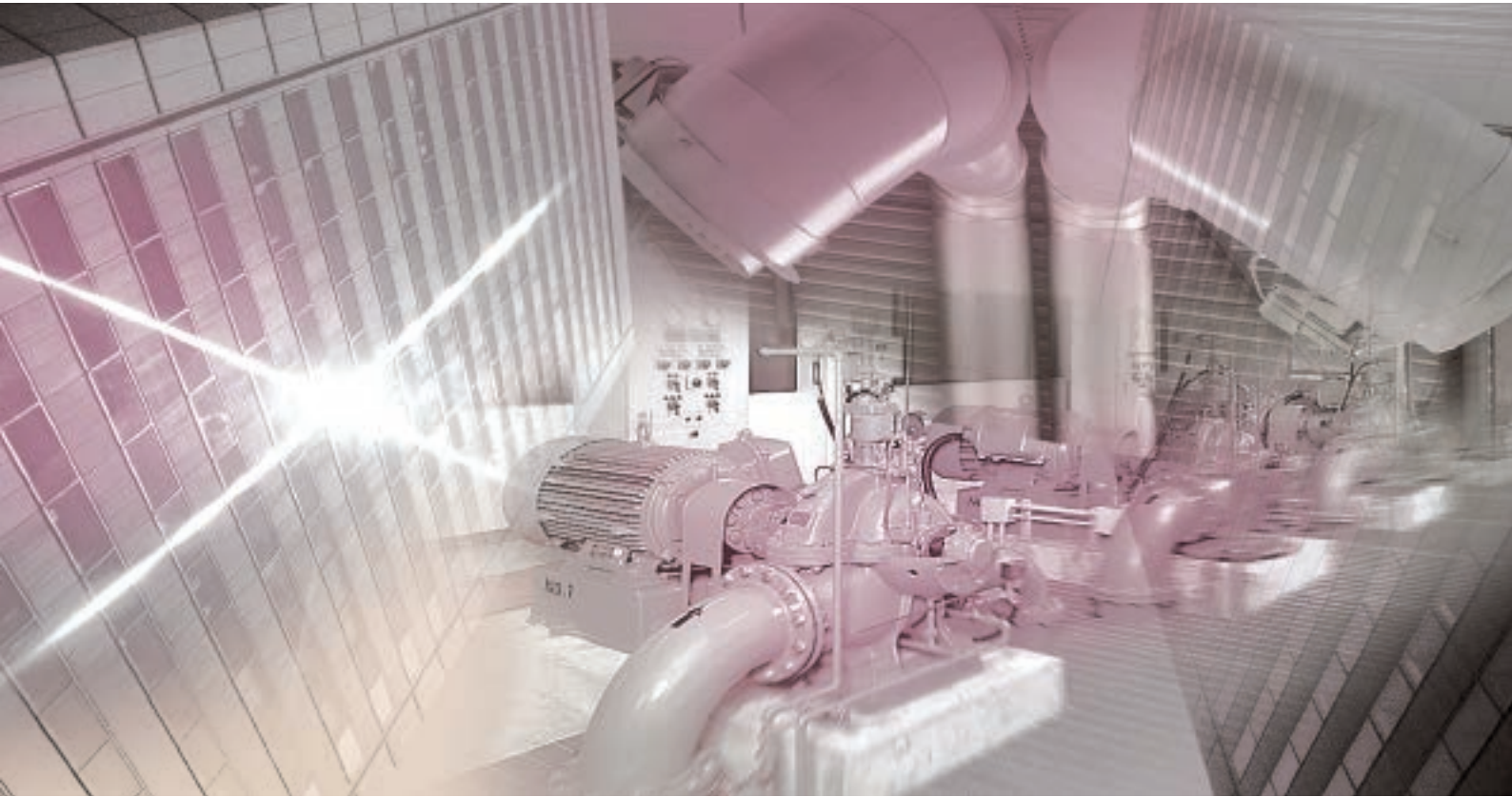

Fluid Applications

Advantages

- 1 Selecting "Fan" or "Pump" presets automatically programs V1000 for optimal performance.
- 2 Compact design saves installation space. Use a permanent magnet motor to shrink the installation even further while conserving impressive amounts of energy.

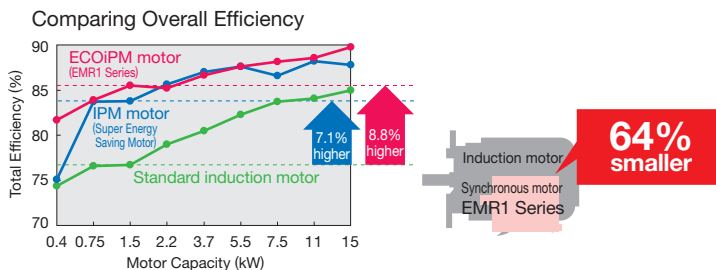

- 3 Pulse output provided to keep track of kilowatt hours-- no power meter needed. (Cannot legally be used as proof of power consumption.)
- 4 Speed Search prevents loss from down time by keeping the application running smoothly through a power loss.
- 5 An optional 24 V power supply lets you monitor drive performance from a PLC even when the power goes out.
- 6 Replace drives immediately and easily thanks to a pluggable terminal board with a built-in Parameter Back-Up function.

Functions

NEW Application Presets	NEW Watt Hour Pulse Monitor	Undertorque Detection
NEW Overexcitation Braking	Energy Saving	Momentary Power Loss Ride-Thru
Speed Search	NEW Drive WorksEZ	Stall Prevention
Multi-Step Speed	NEW PTC Input	NEW Overvoltage Suppression
NEW LOCAL/REMOTE	PID Control	Reference Loss Operation
NEW IM/PM Control	Overtorque Detection	Fault Restart

NEW Functions New software functions for V1000

Applications

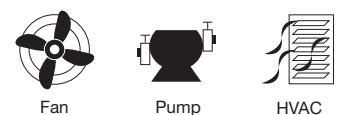

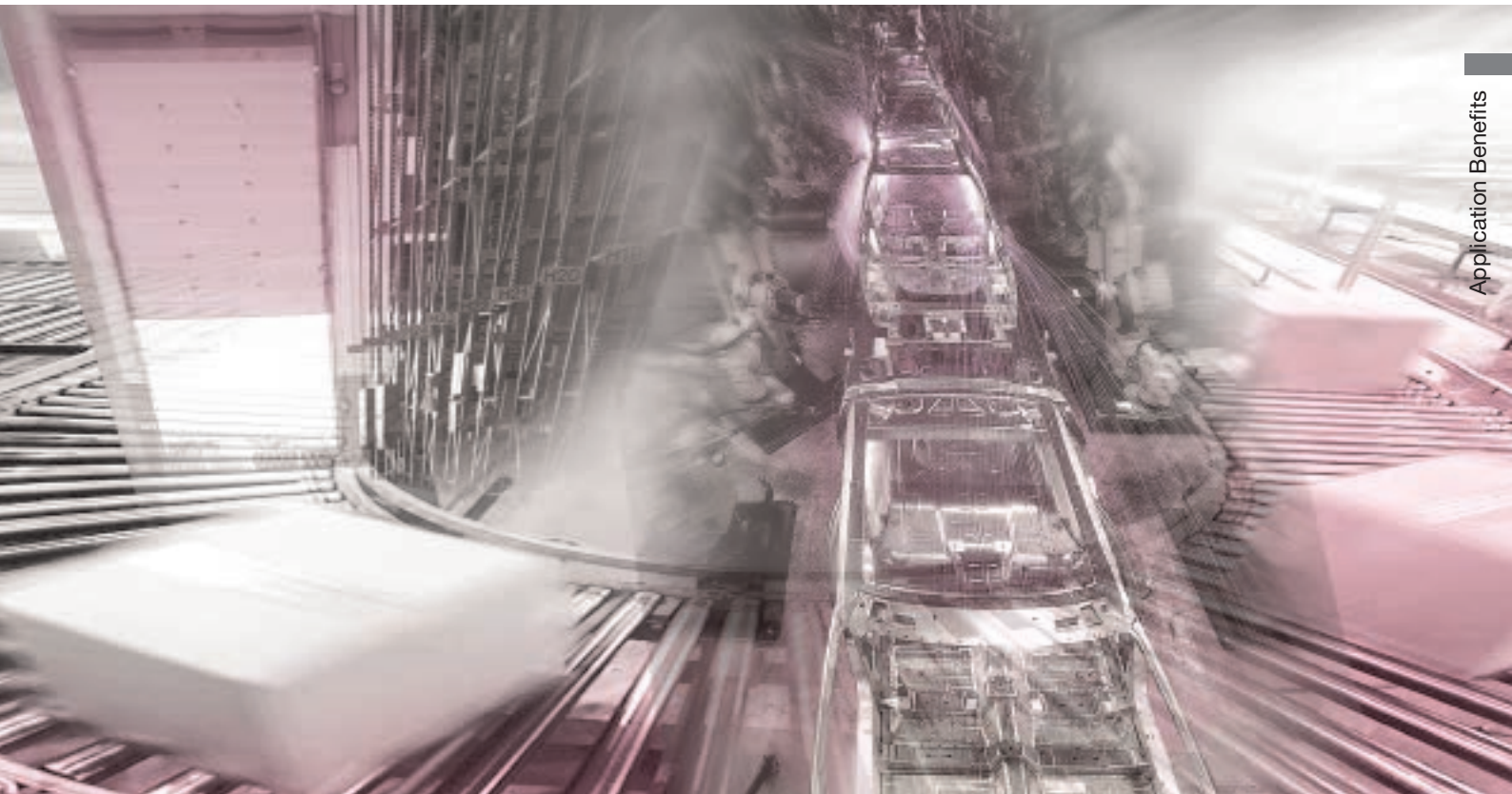

Conveyor, Transport, and Civil Applications

Advantages

- 1 Selecting the “Conveyor” preset automatically programs V1000 for optimal performance.
- 2 Safety input functions standard. Easily complies with various safety regulations.
- 3 Overexcitation braking provides more powerful braking capabilities.
- 4 Easily customize the drive through visual programming with DriveWorksEZ.
- 5 With a variety of communication protocols options available, V1000 can be networked instantly. A separate 24 V power supply is also available, allowing the technician to monitor drive performance from a PLC even when the power goes out.
- 6 IP66 and NEMA 4 Type 1 models are available. Provides water-proof and dust-proof protection and separate installation.

Functions

NEW Application Presets	NEW LOCAL/REMOTE	Pulse Train Output
NEW Overexcitation Braking	NEW IM/PM Control	NEW Torque Limit
S-Curve Characteristics	NEW Online Tuning	NEW Current Vector
Multi-Step Speed	NEW Drive WorksEZ	Stall Prevention
Up/Down	Pulse Train Input	Fault Restart

NEW New Functions New software functions for V1000

Applications





Software Functions

Loaded with software functions just right for your application.

Note: Major functions listed below.

New Functions New V1000 software not available for the V7.

NEW
Application Presets

No need to struggle with difficult parameters and complex calculations. Parameters are set instantly simply by selecting the appropriate Application Preset.

Functions at Start and Stop

NEW
Optimal Deceleration

Optimal deceleration without needing to set the deceleration time. Drive slows the application smoothly controlling DC bus voltage.

NEW
Overexcitation Braking

Perfect for applications with high load inertia that rarely need to be stopped. Stop quickly—50% faster without the use of a braking resistor. Note: Stopping times may vary based on motor characteristics.

DC Injection Braking at Start

Halt a coasting motor and start it back up again. When the direction of a coasting motor is unknown, the drive automatically performs DC Injection to bring the motor to a halt and then start it back up again.

Speed Search

Start a coasting motor. Automatically brings a coasting motor back to the target frequency without the need for extra speed sensors.

Dwell Function

Accelerate and decelerate smoothly with large inertia loads. Drive prevents speed loss by holding the output frequency at a constant level during acceleration and deceleration.

Accel/Decel Time Switch

Switch easily between accel/decel times. Switch acceleration and deceleration rates when running two motors from the same drive, or change accel/decel times when operating at high speed.

S-Curve Characteristics

Prevent sudden shock when starting and stopping the application. Drive lets the user fine-tune the S-curve characteristics, allowing for smooth acceleration and deceleration.

Reference Functions

Frequency Reference Upper/Lower Limits

Limit motor speed. Set speed limits and eliminate the need for extra peripheral devices and extraneous hardware.

Multi-Step Speed

Easily program a speed sequence with multiple steps. Set up to 17 separate speeds to create a speed sequence for the application. The drive can easily be connected to a PLC and allow for a simple positioning with limit switches.

Frequency Jump

Skip over troublesome resonant frequencies. Drive can be programmed to avoid machine resonance problems by avoiding constant speed operation at certain speeds.

Frequency Reference Hold

Improved operability. Momentarily hold the operating frequency during acceleration or deceleration as the load is lowered or raised.

Up/Down

Improved operability. Raise or lower the frequency reference using a remote switch.

NEW
LOCAL/REMOTE

Switch between remote operating locations. Easily switch between controlling the drive directly with the keypad or from a control panel at some remote location.

Functions for Top Performance

NEW
IM/PM Control

Run both IM and PM motors with a single drive. The most advanced motor drive technology can run both IM and PM motors, allowing for even greater energy savings and a more compact setup.

NEW
Watt-Hour Pulse Monitor

No extra watt hour meter needed. A pulse output lets the user monitor power consumption. (Cannot legally be used as proof of power consumption)

Energy Saving

Automatically runs at top efficiency. The drive supplies voltage to the motor relative to the speed and load so that the application is for operating at the most efficient level.

NEW
Online Tuning

Enables high-precision operation. Automatically adjusts resistance between motor conductors during operation, thus improving speed accuracy when there are motor temperature fluctuations. This function is active only for Open Loop Vector Control.

NEW
Current Vector

Achieve high levels of performance. The drive comes with current vector control capabilities for high performance applications.

NEW

Drive
WorksEZ**Customize the perfect drive to fit your needs.**

Upper controller circuitry and drive I/O terminals can be programmed so that extra hardware is no longer needed. Drag-and-drop visual programming makes customization a breeze.

NEW

Timer
Function**No need for extra hardware.**

Control timing by opening and closing the output signal relative to the input signal.

NEW

PTC
Input**Thermal protection provided by a PTC located in the motor windings.**

Protect the motor from over heat by directly connecting the PTC to the drive.

PID
Control**Automatic PID control.**

The internal PID controller fine-adjusts the output frequency for precise control of pressure, flow or other process parameters.

NEW

Motor 2
Switch**One drive runs two motors.**

Use a single drive to operate two different motors. (Only one PM motor may be used)

Pulse Train
Input**Improved operability.**

Use the Pulse Train Input to control not only the frequency reference, but also PID feedback and PID input.

Pulse Train
Output**Improved monitor functions.**

Pulse output lets the user observe everything from the frequency reference and output frequency to motor speed, softstart output frequency, PID feedback, and PID input.

Frequency
Detection**Use frequency detection for brake control.**

The drive can output a signal when the output frequency exceeds a specified level.

Overtorque
Detection**Keep the application running while protecting connected machinery.**

Overtorque detection senses motor torque and notifies the user immediately when a filter clogs or the machine is blocked by mechanical problems.

Undertorque
Detection**Better reliability: Keep the application running while protecting the load.**

Fault detection senses any drop in motor torque due to broken belts or worn transmission.

NEW

Torque
Limit**Better reliability: Keep the application running while protecting the load.**

V1000 helps protect your application by restricting the amount of torque the motor can create.

Protective Functions

Momentary
Power
Loss
Ride-Thru**Keep running even during a momentary loss in power.**

V1000 automatically restarts the motor and keeps the application going in the event of a power loss.

NEW

KEB
Function**Decelerate to stop when the power goes out.**

V1000 uses regenerative energy from the motor to bring the application to a stop, rather than simply letting it coast.

Stall
Prevention**Better reliability: Keep the application running while protecting the load.**

Keeps the machine running by preventing motor stall caused by motor overload or rapid speed changes.

NEW

Overvoltage
Suppression**Avoid overvoltage trip.**

Effective for punching presses and crank shafts where repetitive motion creates large amounts of regenerative energy. The drive increases or decreases the frequency in correspondence with regen levels to prevent overvoltage from occurring.

Reference
Loss
Operation**Better reliability for continuous operation.**

The drive can keep running at the most recent frequency reference it was given in the event that the upper controller should fail. An absolute must for HVAC systems.

Fault
Restart**Keep running when a fault occurs.**

V1000 has full self-diagnostic features and can restart the application in the event of a fault. Up to 10 restarts possible.



Parameter List

The following code is used to indicate whether a parameter is available in a certain control mode or not.

S: Available in the Setup Mode and the Parameter Setting Mode. ○: Available in the Parameter Setting Mode. ×: Not available in this control mode

Refer to V1000 Technical Manual for details.

Function	No.	Name	Range	Def*1	Control Mode			
					V/f	OLV	PM	
Initialization Parameters	A1-00*2	Language Selection	0 to 7	*1	○	○	○	
	A1-01	Access Level Selection	0 to 2	2	○	○	○	
	A1-02	Control Method Selection	0,2,5	0	S	S	S	
	A1-03	Initialize Parameters	0 to 5550	0	○	○	○	
	A1-04	Password 1	0 to 9999	0	○	○	○	
	A1-05*3	Password 2	0 to 9999	0	○	○	○	
	A1-06	Application Preset	0 to 8	0	○	○	○	
User Parameters	A2-01 to A2-32	User Parameters, 1 to 32	b1-01 to o2-08	-	○	○	○	
	A2-33	User Parameter Automatic Selection	0,1	1	○	○	○	
Operation Mode Selection	b1-01	Frequency Reference Selection 1	0 to 4	1	S	S	S	
	b1-02	Run Command Selection 1	0 to 3	1	S	S	S	
	b1-03	Stopping Method Selection	0 to 3	0	S	S	S	
	b1-04	Reverse Operation Selection	0,1	0	○	○	○	
	b1-07	LOCAL/REMOTE Run Selection	0,1	0	○	○	○	
	b1-08	Run Command Selection while in Programming Mode	0 to 2	0	○	○	○	
	b1-14	Phase Order Selection	0,1	0	○	○	○	
	b1-15	Frequency Reference 2	0 to 4	0	○	○	○	
DC Injection Braking	b2-01	DC Injection Braking Start Frequency	0.0 to 10.0	0.5 Hz	○	○	○	
	b2-02	DC Injection Braking Current	0 to 75	50%	○	○	○	
	b2-03	DC Injection Braking Time/DC Excitation Time at Start	0.00 to 10.00	0.00 s	○	○	○	
	b2-04	DC Injection Braking Time at Stop	0.00 to 10.00	0.50 s	○	○	×	
	b2-08	Magnetic Flux Compensation Capacity	0 to 1000	0%	×	○	×	
	b2-12	Short Circuit Brake Time at Start	0.00 to 25.50	0.00 s	×	×	○	
	b2-13	Short Circuit Brake Time at Stop	0.00 to 25.50	0.50 s	×	×	○	
	Speed Search	b3-01	Speed Search Selection	0,1	0	○	○	○
b3-02		Speed Search Deactivation Current	0 to 200	120	○	○	×	
b3-03		Speed Search Deceleration Time	0.1 to 10.0	2.0 s	○	○	×	
b3-05		Speed Search Delay Time	0.0 to 100.0	0.2 s	○	○	○	
b3-06		Output Current 1 during Speed Search	0.0 to 2.0	dep. on drive capacity	○	○	×	
b3-08		Current Control Gain during Speed Search (Speed Estimation Type)	0.00 to 6.00	*4	○	○	○	
b3-10		Speed Search Detection Compensation Gain	1.00 to 1.20	1.05	○	○	×	
b3-14		Bi-Directional Speed Search Selection	0,1	0	○	○	×	
b3-17		Speed Search Restart Current Level	0 to 200	150%	○	○	×	
b3-18		Speed Search Restart Detection Time	0.00 to 1.00	0.10 s	○	○	×	
Timer Function	b3-19	Number of Speed Search Restarts	0 to 10	3	○	○	×	
	b3-24	Speed Search Method Selection	0,1	0	○	○	×	
	b3-25	Speed Search Retry Interval Time	0.0 to 30.0	0.5 s	○	○	○	
	b3-29	Speed Search Induced Voltage Level	0 to 10	10%	×	×	○	
	b4-01	Timer Function On-Delay Time	0.0 to 300.0	0.0 s	○	○	○	
	b4-02	Timer Function Off-Delay Time	0.0 to 300.0	0.0 s	○	○	○	
	PID Control	b5-01	PID Function Setting	0 to 4	0	○	○	○
		b5-02	Proportional Gain Setting (P)	0.00 to 25.00	1.00	○	○	○
		b5-03	Integral Time Setting (I)	0.0 to 360.0	1.0 s	○	○	○
		b5-04	Integral Limit Setting	0.0 to 100.0	100.0%	○	○	○
b5-05		Derivative Time (D)	0.00 to 10.00	0.00 s	○	○	○	
b5-06		PID Output Limit	0.0 to 100.0	100.0%	○	○	○	
b5-07		PID Offset Adjustment	-100.0 to +100.0	0.0%	○	○	○	
b5-08		PID Primary Delay Time Constant	0.00 to 10.00	0.00 s	○	○	○	
b5-09		PID Output Level Selection	0,1	0	○	○	○	
b5-10		PID Output Gain Setting	0.00 to 25.00	1.00	○	○	○	
b5-11		PID Output Reverse Selection	0,1	0	○	○	○	
b5-12		PID Feedback Reference Missing Detection Selection	0 to 5	0	○	○	○	
b5-13		PID Feedback Loss Detection Level	0 to 100	0%	○	○	○	
b5-14		PID Feedback Loss Detection Time	0.0 to 25.5	1.0 s	○	○	○	
b5-15		PID Sleep Function Start Level	0.0 to 400.0	0.0 Hz	○	○	○	
b5-16		PID Sleep Delay Time	0.0 to 25.5	0.0 s	○	○	○	
b5-17		PID Accel/Decel Time	0 to 255	0 s	○	○	○	
b5-18		PID Setpoint Selection	0,1	0	○	○	○	
b5-19		PID Setpoint Value	0.00 to 100.00	0.00%	○	○	○	

Function	No.	Name	Range	Def*1	Control Mode		
					V/f	OLV	PM
PID Control	b5-20	PID Setpoint Scaling	0 to 3	1	○	○	○
	b5-34	PID Output Lower Limit	-100.0 to 100.0	0.0%	○	○	○
	b5-35	PID Input Limit	0 to 1000.0	1000.0%	○	○	○
	b5-36	PID Feedback High Detection Level	0 to 100	100%	○	○	○
	b5-37	PID Feedback High Level Detection Time	0.0 to 25.5	1.0 s	○	○	○
	b5-38	PID Setpoint / User Display	1 to 60000	dep. on drive capacity	○	○	○
	b5-39	PID Setpoint Display Digits	0 to 3	0	○	○	○
	b5-40	Frequency Reference Monitor Content during PID	0,1	0	○	○	○
	b5-47	Reverse Operation Selection 2 by PID Output	0,1	1	○	○	○
	Dwell Function	b6-01	Dwell Reference at Start	0.0 to 400.0	0.0 Hz	○	○
b6-02		Dwell Time at Start	0.0 to 10.0	0.0 s	○	○	○
b6-03		Dwell Frequency at Stop	0.0 to 400.0	0.0 Hz	○	○	○
b6-04		Dwell Time at Stop	0.0 to 10.0	0.0 s	○	○	○
b8-01		Energy Saving Control Selection	0,1	0	○	○	×
b8-02		Energy Saving Gain	0.0 to 10.0	0.7	×	○	×
b8-03		Energy Saving Control Filter Time Constant	0.00 to 10.00	0.50	×	○	×
b8-04		Energy Saving Coefficient Value	0.00 to 655.00	dep. on drive capacity	○	×	×
Energy Saving	b8-05	Power Detection Filter Time	0 to 2000	20 ms	○	×	×
	b8-06	Search Operation Voltage Limit	0 to 100	0%	○	×	×
	C1-01	Acceleration Time 1	0.0 to 6000.0*5	10.0 s	S	S	S
	C1-02	Deceleration Time 1			S	S	S
	C1-03	Acceleration Time 2			○	○	○
	C1-04	Deceleration Time 2			○	○	○
	C1-05	Acceleration Time 3 (Motor 2 Accel Time 1)			○	○	○
	C1-06	Deceleration Time 3 (Motor 2 Decel Time 1)			○	○	○
	C1-07	Acceleration Time 4 (Motor 2 Accel Time 2)			○	○	○
	C1-08	Deceleration Time 4 (Motor 2 Decel Time 2)			○	○	○
	C1-09	Fast-Stop Time	0.0 to 6000.0*5	10.0 s	○	○	○
	C1-10	Accel/Decel Time Setting Units	0,1	1	○	○	○
	C1-11	Accel/Decel Time Switching Frequency	0.0 to 400.0	0.0 Hz	○	○	○
	C1-14	Accel/Decel Rate Frequency	0.0 to 400.0	0.0 Hz	○	○	○
S-Curve Characteristics	C2-01	S-Curve Characteristic at Accel Start	0.00 to 10.00	0.20 s	○	○	○
	C2-02	S-Curve Characteristic at Accel End	0.00 to 10.00	0.20 s	○	○	○
	C2-03	S-Curve Characteristic at Decel Start	0.00 to 10.00	0.20 s	○	○	○
	C2-04	S-Curve Characteristic at Decel End	0.00 to 10.00	0.00 s	○	○	○
Torque Compensation	C3-01	Slip Compensation Gain	0.0 to 2.5	0.0	○	○	×
	C3-02	Slip Compensation Primary Delay Time	0 to 60000	200 ms	○	○	×
	C3-03	Slip Compensation Limit	0 to 250	200%	○	○	×
	C3-04	Slip Compensation Selection during Regeneration	0,1	0	○	○	×
	C3-05	Output Voltage Limit Operation Selection	0,1	0	×	○	×
	C3-18	Output Voltage Limit Level	70.0 to 100.0	90.0%	×	○	×
	C4-01	Torque Compensation Gain	0.00 to 2.50	1.00	○	○	○
	C4-02	Torque Compensation Primary Delay Time	0 to 60000	200 ms	○	○	○
Speed Control (ASR)	C4-03	Torque Compensation at Forward Start	0.0 to 200.0	0.0%	×	○	×
	C4-04	Torque Compensation at Reverse Start	-200.0 to 0.0	0.0%	×	○	×
	C4-05	Torque Compensation Time Constant	0 to 200	10 ms	×	○	×
	C4-06	Torque Compensation Primary Delay Time 2	0 to 10000	150 ms	×	○	×
	C5-01	ASR Proportional Gain 1	0.00 to 300.00	0.20	○	×	×
	C5-02	ASR Integral Time 1	0.000 to 10.000	0.200	○	×	×
Carrier Frequency	C5-03	ASR Proportional Gain 2	0.00 to 300.00	0.02	○	×	×
	C5-04	ASR Integral Time 2	0.000 to 10.000	0.050 s	○	×	×
	C5-05	ASR Limit	0.0 to 20.0	5.0%	○	×	×
	C6-01	Normal/Heavy Duty Selection	0,1	1	S	S	S
	C6-02	Carrier Frequency Selection	1 to B,F	S	S	S	
Frequency Reference	C6-03	Carrier Frequency Upper Limit	1.0 to 15.0	dep. on drive capacity	○	○	○
	C6-04	Carrier Frequency Lower Limit	0.4 to 15.0	○	×	×	
	C6-05	Carrier Frequency Proportional Gain	00 to 99	○	×	×	
	d1-01	Frequency Reference 1	0.00 to 400.00 Hz	0.00 Hz	S	S	S
d1-02	Frequency Reference 2	S			S	S	
d1-03	Frequency Reference 3	S			S	S	
d1-04	Frequency Reference 4	S			S	S	

*1: Default setting depends on the control mode.

*2: Parameter setting value is not reset to the default value during drive initialization, A1-03 = 1110, 2220, 3330.

*3: Parameter A1-05 is hidden from view. To display A1-05, access parameter A1-04 and simultaneously depress the STOP key and the Up arrow key.

*4: If A1-02 = 0 or 2, the default setting depends on the capacity of the drive. If A1-02 = 5, the default setting is 0.30.

*5: The accel/decel time setting range determines the value of the units set to C1-10.

Note: For software version PRG: 1024 or later. Verify the software version by checking either the nameplate on the drive or parameter U1-25.

Function	No.	Name	Range	Def*1	Control Mode					
					V/f	OLV	PM			
Frequency Reference	d1-05	Frequency Reference 5	0.00 to 400.00	0.00 Hz	○	○	○			
	d1-06	Frequency Reference 6			○	○	○			
	d1-07	Frequency Reference 7			○	○	○			
	d1-08	Frequency Reference 8			○	○	○			
	d1-09	Frequency Reference 9			○	○	○			
	d1-10	Frequency Reference 10			○	○	○			
	d1-11	Frequency Reference 11			○	○	○			
	d1-12	Frequency Reference 12			○	○	○			
	d1-13	Frequency Reference 13			○	○	○			
	d1-14	Frequency Reference 14			○	○	○			
	d1-15	Frequency Reference 15			○	○	○			
	d1-16	Frequency Reference 16			○	○	○			
	d1-17	Jog Frequency Reference			0.00 to 400.00	6.00 Hz	S	S	S	
	Frequency Upper and Lower Limits	d2-01			Frequency Reference Upper Limit	0.0 to 110.0	100.0%	○	○	○
		d2-02			Frequency Reference Lower Limit	0.0 to 110.0	0.0%	○	○	○
		d2-03			Master Speed Reference Lower Limit	0.0 to 110.0	0.0%	○	○	○
		d3-01	Jump Frequency 1	0.0 to 400.0	0.0 Hz	○	○	○		
Jump Frequency	d3-02	Jump Frequency 2	0.0 to 400.0	0.0 Hz	○	○	○			
	d3-03	Jump Frequency 3	0.0 to 400.0	0.0 Hz	○	○	○			
	d3-04	Jump Frequency Width	0.0 to 20.0	1.0 Hz	○	○	○			
	Frequency Reference Hold	d4-01	Frequency Reference Hold Function Selection	0,1	0	○	○	○		
d4-03		Frequency Reference Bias Step (Up/Down 2)	0.00 to 99.99	0.00 Hz	○	○	○			
d4-04		Frequency Reference Bias Accel/Decel (Up/Down 2)	0,1	0	○	○	○			
d4-05		Frequency Reference Bias Operation Mode Selection (Up/Down 2)	0,1	0	○	○	○			
d4-06		Frequency Reference Bias (Up/Down 2)	-99.9 to +100.0	0.0%	○	○	○			
d4-07		Analog Frequency Reference Fluctuation Limit (Up/Down 2)	0.1 to +100.0	1.0%	○	○	○			
d4-08		Frequency Reference Bias Upper Limit (Up/Down 2)	0.0 to 100.0	100.0%	○	○	○			
d4-09		Frequency Reference Bias Lower Limit (Up/Down 2)	-99.9 to 0.0	0.0%	○	○	○			
d4-10		Up/Down Frequency Reference Limit Selection	0,1	0	○	○	○			
Offset Frequency		d7-01	Offset Frequency 1	-100.0 to +100.0	0.0%	○	○	○		
	d7-02	Offset Frequency 2	-100.0 to +100.0	0.0%	○	○	○			
	d7-03	Offset Frequency 3	-100.0 to +100.0	0.0%	○	○	○			
V/f Pattern Characteristics	E1-01*2	Input Voltage Setting	155 to 255	dep. on drive capacity	S	S	S			
	E1-03	V/f Pattern Selection	0 to F	F	○	○	×			
	E1-04	Max Output Frequency	40.0 to 400.0	60.0 Hz	S	S	S			
	E1-05*2	Max Output Voltage	0.0 to 255.0	200.0 V	S	S	S			
	E1-06	Base Frequency	0.0 to E1-04	60.0 Hz	S	S	S			
	E1-07	Mid Output Frequency	0.0 to E1-04	3.0 Hz	○	○	○			
	E1-08*2	Mid Output Frequency Voltage	0.0 to 255.0	16.0 V	○	○	×			
	E1-09	Minimum Output Freq.	0.0 to E1-04	1.5 Hz	S	S	S			
	E1-10*2	Minimum Output Freq. Voltage	0.0 to 255.0	9.0 V	○	○	×			
	E1-11	Mid Output Frequency 2	0.0 to E1-04	0.0 Hz	○	○	×			
	E1-12*2	Mid Output Frequency Voltage 2	0.0 to 255.0	0.0 V	○	○	×			
	E1-13*2	Base Voltage	0.0 to 255.0	0.0 V	○	S	×			
	Motor Parameters	E2-01	Motor Rated Current	10 to 200% of drive rated current	dep. on drive capacity	S	S	×		
E2-02		Motor Rated Slip	0.00 to 20.00	dep. on drive capacity	○	○	×			
E2-03		Motor No-Load Current	0 to less than E2-01	○	○	×				
E2-04		Number of Motor Poles	2 to 48	4 poles	○	○	×			
E2-05		Motor Line-to-Line Resistance	0.000 to 65.000	dep. on drive capacity	○	○	×			
E2-06		Motor Leakage Inductance	0.0 to 40.0	○	○	×				
E2-07		Motor Iron-Core Saturation Coefficient 1	E2-07 to 0.50	0.50	×	○	×			
E2-08		Motor Iron-Core Saturation Coefficient 2	E2-07 to 0.75	0.75	×	○	×			
E2-09		Motor Mechanical Loss	0.0 to 10.0	0.0%	×	○	×			
E2-10		Motor Iron Loss for Torque Compensation	0 to 65535	dep. on drive capacity	○	×	×			
E2-11		Motor Rated Output	0.00 to 650.00	0.40 kW	S	S	×			
E2-12		Motor Iron-Core Saturation Coefficient 3	1.30 to 5.00	1.30	×	○	×			
Motor 2 V/f Characteristics	E3-01	Motor 2 Control Method	0,2	0	○	○	×			
	E3-04	Motor 2 Max Output Frequency	40.0 to 400.0	60.0 Hz	○	○	×			
	E3-05*2	Motor 2 Max Voltage	0.0 to 255.0	200.0 V	○	○	×			
	E3-06	Motor 2 Base Frequency	0.0 to E3-04	60.0 Hz	○	○	×			
	E3-07	Motor 2 Mid Output Freq.	0.0 to E3-04	3.0 Hz	○	○	×			
	E3-08*2	Motor 2 Mid Output Freq. Voltage	0.0 to 255.0	16.0 V	○	○	×			
	E3-09	Motor 2 Min. Output Freq.	0.0 to E3-04	1.5 Hz	○	○	×			

*1: Default setting depends on the control mode.

*2: Values shown here are for 200 V class drives. Double the value when using a 400 V class drive.

Function	No.	Name	Range	Def*1	Control Mode			
					V/f	OLV	PM	
Motor 2 V/f Characteristics	E3-10	Motor 2 Min. Output Freq. Voltage	0.0 to 255.0	12.0 V	○	○	×	
	E3-11	Motor 2 Mid Output Frequency 2	0.0 to E3-04	0.0 Hz	○	○	×	
Motor 2 Parameters	E3-12*2	Motor 2 Mid Output Frequency Voltage 2	0.0 to 255.0	0.0 Vac	○	○	×	
	E3-13*2	Motor 2 Base Voltage	0.0 to 255.0	0.0 Vac	○	S	×	
	E4-01	Motor 2 Rated Current	10 to 200% of drive rated current	dep. on drive capacity	○	○	×	
	E4-02	Motor 2 Rated Slip	0.00 to 20.00	○	○	×		
	E4-03	Motor 2 Rated No-Load Current	0 to less than E4-01	○	○	×		
	E4-04	Motor 2 Motor Poles	2 to 48	4 poles	○	○	×	
	E4-05	Motor 2 Line-to-Line Resistance	0.000 to 65.000	dep. on drive capacity	○	○	×	
	E4-06	Motor 2 Leakage Inductance	0.0 to 40.0	○	○	×		
	E4-07	Motor 2 Motor Iron-Core Saturation Coefficient 1	0.00 to 0.50	0.50	×	○	×	
	E4-08	Motor 2 Motor Iron-Core Saturation Coefficient 2	Setting for E4-07 to 0.75	0.75	×	○	×	
	E4-09	Motor 2 Mechanical Loss	0.0 to 10.0	0.0	×	○	×	
	E4-10	Motor 2 Iron Loss	0 to 65535	dep. on drive capacity	○	×	×	
	E4-11	Motor 2 Rated Capacity	0.00 to 650.00	○	○	×		
	E4-12	Motor 2 Iron-Core Saturation Coefficient 3	1.30 to 5.00	1.30	×	○	×	
	E4-14	Motor 2 Slip Compensation Gain	0.0 to 2.5	0.0	○	○	×	
	E4-15	Torque Compensation Gain - Motor 2	1.00 to 2.50	1.00	○	○	×	
	PM Motor Parameters	E5-01	Motor Code Selection (for PM motor)	0000 to FFFF		×	×	S
E5-02		Motor Rated Capacity (for PM motor)	0.10 to 18.50		×	×	S	
E5-03		Motor Rated Current	10 to 200% of drive rated current	dep. on drive capacity	×	×	S	
E5-04		Motor Poles	2 to 48		×	×	S	
E5-05		Motor Resistance	0.000 to 65.000		×	×	S	
E5-06		Motor d Axis Inductance	0.00 to 300.00		×	×	S	
E5-07		Motor q Axis Inductance	0.00 to 600.00		×	×	S	
E5-09		Motor Induction Voltage Constant 1	0.0 to 2000.0		×	×	S	
E5-24		Motor Induction Voltage Constant 2	0.0 to 6000.0		×	×	S	
E5-39		Current Detection Delay Time	-1000 to +1000	0 μs	○	○	○	
V/f Control with Simple PG Feedback - PG Setup Parameters		F1-02	Operation Selection at PG Open Circuit (PGo)	0 to 3	1	○	×	×
	F1-03	Operation Selection at Overspeed (oS)	0 to 3	1	○	×	×	
	F1-04	Operation Selection at Deviation	0 to 3	3	○	×	×	
	F1-08	Overspeed Detection Level	0 to 120	115%	○	×	×	
	F1-09	Overspeed Detection Delay Time	0.0 to 2.0	1.0	○	×	×	
	F1-10	Excessive Speed Deviation Detection Level	0 to 50	10%	○	×	×	
	F1-11	Excessive Speed Deviation Detection Delay Time	0.0 to 10.0	0.5 s	○	×	×	
	F1-14	PG Open-Circuit Detection Time	0.0 to 10.0	2.0 s	○	×	×	
	Serial Communications Option Card Settings	F6-01	Communications Error Operation Selection	0 to 5	1	○	○	○
		F6-02	External Fault from Comm. Option Selection	0,1	0	○	○	○
F6-03		External Fault from Comm. Option Operation Selection	0 to 3	1	○	○	○	
F6-04		Bus Error Detection Time	0.0 to 5.0	2.0 s	○	○	○	
F6-07		Multi-Step Speed during NefRef/ComRef	0,1	1	○	○	○	
F6-08		Reset Communication Parameters	0,1	0	○	○	○	
F6-10		CC-Link Node Address	0 to 63	0	○	○	○	
F6-11		CC-Link Communications Speed	0 to 4	0	○	○	○	
F6-14		BUS Error Auto Reset	0,1	0	○	○	○	
F6-20		MECHATROLINK Station Address	20H to 3FH	21	○	○	○	
F6-21		MECHATROLINK Frame Size	0,1	0	○	○	○	
F6-22		MECHATROLINK Link Speed	0,1	0	○	○	○	
F6-23		MECHATROLINK Monitor Selection (E)	0 to FFFFH	0	○	○	○	
F6-24		MECHATROLINK Monitor Selection (F)	0 to FFFFH	0	○	○	○	
F6-25		MECHATROLINK-II WDT Error Selection	0 to 3	1	○	○	○	
F6-26		MECHATROLINK-II bUS Errors	2 to 10	2	○	○	○	
F6-30		PROFIBUS Node Address	0 to 125	0	○	○	○	
F6-31		PROFIBUS Clear Mode Selection	0,1	0	○	○	○	
F6-32	PROFIBUS Data Format Selections	0,1	0	○	○	○		
F6-35	CANopen Node ID Selection	0 to 126	99	○	○	○		
F6-36	CANopen Communications Speed	0 to 8	6	○	○	○		
F6-40	CompoNet Node ID	0 to 63	0	○	○	○		
F6-41	CompoNet Speed	0 to 255	0	○	○	○		
F6-50	DeviceNet MAC Address	0 to 63	*1	○	○	○		
F6-51	DeviceNet Communications Speed	0 to 4	*1	○	○	○		
F6-52	DeviceNet / CompoNet PCA Setting	0 to 255	21	○	○	○		
F6-53	DeviceNet / CompoNet PPA Setting	0 to 255	71	○	○	○		

Parameter List (continued)

Function	No.	Name	Range	Def*1	Control Mode		
					V/f	OLV	PM
Serial Communications Option Card Settings	F6-54	DeviceNet Idle Mode Fault Detection	0,1	0	○	○	○
	F6-55	DeviceNet Baud Rate from Network	0 to 2 (read only)	—	○	○	○
	F6-56	DeviceNet / CompoNet Speed Scaling Factor	- 15 to 15	0	○	○	○
	F6-57	DeviceNet / CompoNet Current Scaling Factor	- 15 to 15	0	○	○	○
	F6-58	DeviceNet / CompoNet Torque Scaling Factor	- 15 to 15	0	○	○	○
	F6-59	DeviceNet / CompoNet Power Scaling Factor	- 15 to 15	0	○	○	○
	F6-60	DeviceNet / CompoNet Voltage Scaling Factor	- 15 to 15	0	○	○	○
	F6-61	DeviceNet / CompoNet Time Scaling Factor	- 15 to 15	0	○	○	○
	F6-62	DeviceNet Heartbeat Interval	0 to 10	0	○	○	○
	F6-63	DeviceNet MAC ID from Network	0 to 63 (read only)	—	○	○	○
Multi-Function Digital Inputs	H1-01	Multi-Function Digital Input Terminal S1 Function Selection	1 to 9F	40	○	○	○
	H1-02	Multi-Function Digital Input Terminal S2 Function Selection		41	○	○	○
	H1-03	Multi-Function Digital Input Terminal S3 Function Selection		24	○	○	○
	H1-04	Multi-Function Digital Input Terminal S4 Function Selection		14	○	○	○
	H1-05	Multi-Function Digital Input Terminal S5 Function Selection		3(0)	○	○	○
	H1-06	Multi-Function Digital Input Terminal S6 Function Selection		4(3)	○	○	○
	H1-07	Multi-Function Digital Input Terminal S7 Function Selection		6(4)	○	○	○
	Multi-Function Digital Outputs	H2-01		Terminal MA, MB and MC Function Selection (relay)	0 to 192	E	○
H2-02		Terminal P1 Function Selection (open-collector)	0	○		○	○
H2-03		Terminal P2 Function Selection (open-collector)	2	○		○	○
H2-06		Watt Hour Output Unit Selection	0 to 4	0		○	○
Analog Inputs	H3-01	Terminal A1 Signal Level Selection	0,1	0	○	○	○
	H3-02	Terminal A1 Function Selection	0 to 31	0	○	○	○
	H3-03	Terminal A1 Gain Setting	-999.9 to 999.9	100.0%	○	○	○
	H3-04	Terminal A1 Bias Setting	-999.9 to 999.9	0.0%	○	○	○
	H3-09	Terminal A2 Signal Level Selection	0 to 3	2	○	○	○
	H3-10	Terminal A2 Function Selection	0 to 31	0	○	○	○
	H3-11	Terminal A2 Gain Setting	-999.9 to 1000.0	100.0%	○	○	○
	H3-12	Terminal A2 Input Bias	-999.9 to 999.9	0.0%	○	○	○
	H3-13	Analog Input Filter Time Constant	0.00 to 2.00	0.03 s	○	○	○
	H3-14	Analog Input Terminal Enable Selection	1,2,7	7	○	○	○
Multi-Function Analog Outputs	H4-01	Multi-Function Analog Output Terminal AM	000 to 999	102	○	○	○
	H4-02	Multi-Function Analog Output Terminal AM Gain	- 999.9 to 999.9	100.0%	S	S	S
	H4-03	Multi-Function Analog Output Terminal AM Bias	- 999.9 to 999.9	0.0%	○	○	○
MEWOBUS/Modbus Communications	H5-01	Drive Slave Address	0 to 20 H	1F	○	○	○
	H5-02	Communication Speed Selection	0 to 8	3	○	○	○
	H5-03	Communication Parity Selection	0 to 2	0	○	○	○
	H5-04	Stopping Method After Communication Error	0 to 3	3	○	○	○
	H5-05	Communication Fault Detection Selection	0,1	1	○	○	○
	H5-06	Drive Transmit Wait Time	5 to 65	5 ms	○	○	○
	H5-07	RTS Control Selection	0,1	1	○	○	○
	H5-09	CE Detection Time	0.0 to 10.0	2.0 s	○	○	○
	H5-10	Unit Selection for MEMOBUS/ Modbus Register 0025H	0,1	0	○	○	○
	H5-11	Communications ENTER Function Selection	0,1	1	○	○	○
	H5-12	Run Command Method Selection	0,1	0	○	○	○
	Pulse Train Input/Output	H6-01	Pulse Train Input Terminal RP Function Selection	0 to 3	0	○	○
H6-02		Pulse Train Input Scaling	100 to 32000	1440 Hz	○	○	○
H6-03		Pulse Train Input Gain	0.0 to 1000.0	100.0%	○	○	○
H6-04		Pulse Train Input Bias	-100.0 to +100.0	0.0%	○	○	○
H6-05		Pulse Train Input Filter Time	0.00 to 2.00	0.10 s	○	○	○

Function	No.	Name	Range	Def*1	Control Mode		
					V/f	OLV	PM
Pulse Train Input/Output	H6-06	Pulse Train Monitor Terminal MP Selection	000,031,101,102,105,116,501,502	102	○	○	○
	H6-07	Pulse Train Monitor Scaling	0 to 32000	1440 Hz	○	○	○
	H6-08	Pulse Train Input Minimum Frequency	0.1 to 1000.0	0.5 Hz	○	○	○
	L1-01	Motor Overload Protection Selection	0 to 4,6	1	S	S	S
	L1-02	Motor Overload Protection Time	0.1 to 5.0	1.0 min	○	○	○
	L1-03	Motor Overheat Alarm Operation Selection (PTC input)	0 to 3	3	○	○	○
	L1-04	Motor Overheat Fault Operation Selection (PTC input)	0 to 2	1	○	○	○
	L1-05	Motor Temperature Input Filter Time (PTC input)	0.00 to 10.00	0.20 s	○	○	○
	L1-13	Continuous Electrothermal Operation Selection	0,1	1	○	○	○
	L1-22*2	Leakage Current Filter 1	0.0 to 60.0	20.0	○	○	○
Motor Protection Functions	L1-23*2	Leakage Current Filter 2	0.0 to 60.0	1.0	○	○	○
	L2-01	Momentary Power Loss Operation Selection	0 to 2	0	○	○	○
	L2-02	Momentary Power Loss Ride-Thru Time	0.0 to 25.5		○	○	○
	L2-03	Momentary Power Loss Minimum Baseblock Time	0.1 to 5.0	dep. on drive capacity	○	○	○
	L2-04	Momentary Power Loss Voltage Recovery Ramp Time	0.0 to 5.0		○	○	○
	L2-05*3	Undervoltage Detection Level (Uv)	150 to 210		○	○	○
	L2-06	KEB Deceleration Time	0.0 to 200.0	0.0 s	○	○	○
	L2-07	KEB Acceleration Time	0.0 to 25.5	0.0 s	○	○	○
	L2-08	KEB Start Output Frequency Reduction	0 to 300	100%	○	○	○
	L2-11*3	Desired DC Bus Voltage during KEB	150 to 400	E1-01×1.22 (V)	○	○	○
Momentary Power Loss	L3-01	Stall Prevention Selection during Acceleration	0 to 2	1	○	○	○
	L3-02	Stall Prevention Level during Acceleration	0 to 150	dep. on drive capacity	○	○	○
	L3-03	Stall Prevention Limit during Acceleration	0 to 100	50%	○	○	○
	L3-04	Stall Prevention Selection during Deceleration	0 to 4,7	1	S	S	S
	L3-05	Stall Prevention Selection during Run	0 to 2	1	○	×	○
	L3-06	Stall Prevention Level during Run	30 to 150	dep. on drive capacity	○	×	○
	L3-11	ov Suppression Function Selection	0,1	0	○	○	○
	L3-17*3	Overvoltage Suppression and Stall Prevention Desired DC Bus Voltage	150 to 400	370 V	○	○	○
	L3-20	Main Power Circuit Voltage Adjustment Gain	0.00 to 5.00	1.00	○	○	○
	L3-21	Accel/Decel Rate Calculation Gain	0.00 to 200.00	1.00	○	○	○
Stall Prevention Functions	L3-22	Deceleration Time at Stall Prevention during Acceleration	0.0 to 6000.0	0.0 s	×	×	○
	L3-23	Automatic Reduction Selection for Stall Prevention during Run	0,1	0	○	○	○
	L3-24	Motor Acceleration Time for Inertia Calculations	0.001 to 10,000	dep. on drive capacity	○	○	○
	L3-25	Load Inertia Ratio	0.0 to 1000.0	1.0	○	○	○
	L4-01	Speed Agreement Detection Level	0.0 to 400.0	0.0 Hz	○	○	○
	L4-02	Speed Agreement Detection Width	0.0 to 20.0	2.0 Hz	○	○	○
	L4-03	Speed Agreement Detection Level (+/-)	-400.0 to 400.0	0.0 Hz	○	○	○
	L4-04	Speed Agreement Detection Width (+/-)	0.0 to 20.0	2.0 Hz	○	○	○
	L4-05	Frequency Reference Loss Detection Selection	0,1	0	○	○	○
	L4-06	Frequency Reference at Reference Loss	0.0 to 100.0	80.0%	○	○	○
Frequency Detection	L4-07	Frequency Detection Conditions	0,1	0	○	○	○
	L4-08	Speed Agreement Condition Selection	0,1	0	○	○	○
	L5-01	Number of Auto Restart Attempts	0 to 10	0	○	○	○
	L5-02	Auto Restart Operation Selection	0,1	0	○	○	○
	L5-04	Fault Reset Interval Time	0.5 to 600.0	10.0 s	○	○	○
	L5-05	Fault Reset Operation Selection	0,1	0	○	○	○
	L6-01	Torque Detection Selection 1	0 to 8	0	○	○	○
	L6-02	Torque Detection Level 1	0 to 300	150%	○	○	○
	L6-03	Torque Detection Time 1	0.0 to 10.0	0.1 s	○	○	○
	L6-04	Torque Detection Selection 2	0 to 8	0	○	○	○
Overtorque Detection	L6-05	Torque Detection Level 2	0 to 300	150%	○	○	○
	L6-06	Torque Detection Time 2	0.0 to 10.0	0.1 s	○	○	○
	L6-08	Mechanical Weakening (oL5) Detection Operation	0 to 8	0	○	○	○
	L6-09	Mechanical Weakening Detection Speed Level	-110.0 to 110.0	110%	○	○	○
	L6-10	Mechanical Weakening Detection Time	0.0 to 10.0	0.1 s	○	○	○
	L6-11	Mechanical Weakening Detection Start Time	0 to 65535	0	○	○	○

*1: Default setting depends on the control mode.
 *2: L1-22 and L1-23 can only be displayed / setting when C6-02=B.
 *3: Values shown here are for 200 V class drives. Double the value when using a 400 V class drive.

Function	No.	Name	Range	Def*1	Control Mode		
					V/f	OLV	PM
Torque Limit	L7-01	Forward Torque Limit	0 to 300	200%	×	○	×
	L7-02	Reverse Torque Limit	0 to 300	200%	×	○	×
	L7-03	Forward Regenerative Torque Limit	0 to 300	200%	×	○	×
	L7-04	Reverse Regenerative Torque Limit	0 to 300	200%	×	○	×
	L7-06	Torque Limit Integral Time Constant	5 to 10000	200 ms	×	○	×
	L7-07	Torque Limit Control Method Selection during Accel/Decel	0,1	0	×	○	×
	Hardware Protection	L8-01	Internal Dynamic Braking Resistor Protection Selection (ERF type)	0,1	0	○	○
L8-02		Overheat Alarm Level	50 to 130	dep. on drive capacity	○	○	○
L8-03		Overheat Pre-Alarm Operation Selection	0 to 4	3	○	○	○
L8-05		Input Phase Loss Protection Selection	0,1	0	○	○	○
L8-07		Output Phase Loss Protection	0 to 2	1	○	○	○
L8-09		Output Ground Fault Detection Selection	0,1	dep. on drive capacity	○	○	○
L8-10		Heatsink Cooling Fan Operation Selection	0,1	0	○	○	○
L8-11		Heatsink Cooling Fan Operation Delay Time	0 to 300	60 s	○	○	○
L8-12		Ambient Temperature Setting	-10 to 50	40°C	○	○	○
L8-15		OL2 Characteristics Selection at Low Speeds	0,1	1	○	○	○
L8-18		Soft CLA Selection	0,1	dep. on C6-02	○	○	×
L8-19		Frequency Reduction Rate during oH Pre-Alarm	0.1 to 1.0	0.8	○	○	○
L8-29		Current Unbalance Detection (LF2)	0,1	1	×	×	○
L8-35		Installation Method Selection	0 to 3	dep. on drive capacity	○	○	○
L8-38		Carrier Frequency Reduction	0 to 2	○	○	○	○
L8-40		Carrier Frequency Reduction Time	0.00 to 2.00	0.50	○	○	○
L8-41		High Current Alarm Selection	0,1	0	○	○	○
L8-51		STO Level	0.0 to 150.0	0.0%	×	×	○
L8-54	STO Bias Detection Selection	0,1	1	×	×	○	
Hunting Prevention	n1-01	Hunting Prevention Selection	0,1	1	○	×	×
	n1-02	Hunting Prevention Gain Setting	0.00 to 2.50	1.00	○	×	×
	n1-03	Hunting Prevention Time Constant	0 to 500	dep. on drive capacity	○	×	×
	n1-05	Hunting Prevention Gain while in Reverse	0.00 to 2.50	0.00	○	×	×
	Speed Feedback Detection Control Function	n2-01	Speed Feedback Detection Control (AFR) Gain	0.00 to 10.00	1.00	×	○
n2-02		Speed Feedback Detection Control (AFR) Time Constant	0 to 2000	50 ms	×	○	×
n2-03		Speed Feedback Detection Control (AFR) Time Constant 2	0 to 2000	750 ms	×	○	×
High-Slip Braking		n3-01	High-Slip Braking Deceleration Frequency Width	1 to 20	5%	○	×
	n3-02	High-Slip Braking Current Limit	100 to 200	150%	○	×	×
	n3-03	High-Slip Braking Dwell Time at Stop	0.0 to 10.0	1.0 s	○	×	×
	n3-04	High-Slip Braking Overload Time	30 to 1200	40 s	○	×	×
	n3-13	Overexcitation Deceleration Gain	1.00 to 1.40	1.10	○	○	×
	n3-21	High-Slip Suppression Current Level	0 to 150	100%	○	○	×
	n3-23	Overexcitation Operation Selection	0 to 2	0	○	○	×
Online Tuning of Motor Line-to-Line Resistance	n6-01	Line-to-Line Motor Resistance Online Tuning	0,1	1	×	○	×
Permanent Magnet (PM) Motor Control	n8-45	Speed Feedback Detection Control Gain	0.0 to 10.0	0.8	×	×	○
	n8-47	Pull-In Current Compensation Time Constant	0.0 to 100.0	5.0 s	×	×	○
	n8-48	Pull-In Current	0.20 to 200	30%	×	×	○
	n8-49	Load Current	-200.0 to 200.0	0.0%	×	×	○
	n8-51	Acceleration Pull-In Current	0 to 200	50%	×	×	○
	n8-54	Voltage Error Compensation Time Constant	0.00 to 10.00	1.00 s	×	×	○
	n8-55	Load Inertia	0 to 3	0	×	×	○
	n8-62*2	Output Voltage Limit	0.0 to 230.0	200.0 V	×	×	○
	n8-63	Output Voltage Limit Gain 1	0.00 to 100.00	1.00	×	×	○
	n8-65	Speed Feedback Detection Control Gain during ov Suppression	0.00 to 10.00	1.50	×	×	○
	n8-68	Output Voltage Limit Gain 2	0.50 to 1.50	0.95	×	×	○
	n8-87	Output Voltage Limit Selection	0,1	0	×	×	○
n8-88	Output Voltage Limit Switch Current Level	0 to 400	400%	×	×	○	
n8-89	Output Voltage Limit Switch Current Hysteresis	0 to n8-88	3%	×	×	○	
n8-90	Output Voltage Limit Switch Speed	0 to 200	200%	×	×	○	
Display Settings	o1-01	Drive Mode Unit Monitor Selection	104 to 810	106	○	○	○
	o1-02	User Monitor Selection After Power Up	1 to 5	1	○	○	○
	o1-03	Digital Operator Display Selection	0 to 3	0	○	○	○
	o1-05	LCD Contrast Control	0 to 5	3	○	○	○
	o1-10	Frequency Reference Setting and User-Set Display	1 to 60000	dep. on drive capacity	○	○	○
	o1-11	Frequency Reference Setting / Decimal Display	0 to 3	○	○	○	○

Function	No.	Name	Range	Def*1	Control Mode		
					V/f	OLV	PM
Operator Keypad Functions	o2-01	LO/RE Key Function Selection	0,1	1	○	○	○
	o2-02	STOP Key Function Selection	0,1	1	○	○	○
	o2-03	User Parameter Default Value	0 to 2	0	○	○	○
	o2-04	Drive Model Selection	0 to FF	dep. on drive capacity	○	○	○
	o2-05	Frequency Reference Setting Method Selection	0,1	0	○	○	○
	o2-06	Operation Selection when Digital Operator is Disconnected	0,1	0	○	○	○
	o2-07	Motor Direction at Power Up when Using Operator	0,1	0	○	○	○
	o2-09	Initialization mode	0 to 3	dep. on drive spec.	○	○	○
	Optional Functions	o3-01	Copy Function Selection	0 to 3	0	○	○
o3-02		Copy Allowed Selection	0,1	0	○	○	○
Maintenance Period	o4-01	Accumulated Operation Time Setting	0 to 9999	0	○	○	○
	o4-02	Accumulated Operation Time Selection	0,1	0	○	○	○
	o4-03	Cooling Fan Operation Time Setting	0 to 9999	0	○	○	○
	o4-05	Capacitor Maintenance Setting	0 to 150	0%	○	○	○
	o4-07	Soft Charge Bypass Relay Maintenance Setting	0 to 150	0%	○	○	○
	o4-09	IGBT Maintenance Setting	0 to 150	0%	○	○	○
	o4-11	U2, U3 Initialize Selection	0,1	0	○	○	○
	o4-12	kWh Monitor Initialize Selection	0,1	0	○	○	○
	o4-13	Number of Run Commands Initialize Selection	0,1	0	○	○	○
	DWEZ Parameters	q1-01 to q6-07	DWEZ Parameters	-	-	○	○
r1-01 to r1-40		DWEZ Connection Parameters	0000 to FFFF(H)	0	×	○	○
Motor Tuning	T1-00	Motor Selection 1/2	1,2	1	○	○	×
	T1-01	Auto-Tuning Mode Selection	0,2,3	dep. on drive capacity	○	○	×
	T1-02	Motor Rated Power	0.03 to 650.00	○	○	×	×
	T1-03*2	Motor Rated Voltage	0.0 to 255.5	200.0 V	○	○	×
	T1-04	Motor Rated Current	10 to 200% of drive rated current	dep. on drive capacity	○	○	×
	T1-05	Motor Base Frequency	0.0 to 400.0	60.0 Hz	○	○	×
	T1-06	Number of Motor Poles	2 to 48	4	○	○	×
	T1-07	Motor Base Speed	0 to 24000	1750 r/min	○	○	×
	T1-11	Motor Iron Loss	0 to 65535	14 W	○	×	×

*1: Default setting depends on the control mode.
*2: Values shown here are for 200 V class drives. Double the value when using a 400 V class drive.

Basic Instructions

Outstanding operability! Separate settings for each application enables quick set-up.



Operator Names and Functions

Data display (5-digit)
Displays frequency, parameter number, and other data.

LO/RE light
Lights to indicate that the operator is set for LOCAL.

ESC key
Lets the user back up to the previous display screen.

Right arrow key
Scrolls the cursor to the right.

RESET key
Resets a fault.

RUN light
Lights when the Run command is present.

RUN key
Issues a Run command.

Glossary
Used as a quick guide for the abbreviations used on the display screen. Details listed on the next page.



LED panel
More information listed below.

LO/RE key
Determines where the Run command and frequency reference come from: the keypad (LOCAL) or the control terminals (REMOTE).

ENTER key
Press to enter values, edit parameters, and set the control mode. Press this key to proceed to the next screen when scrolling through various menu displays.

Com port
For connecting to a PC (DriveWizard or DriveWorksEZ), a USB copy unit or a LCD operator.

Up arrow key
Scrolls up through the display screen, and increases a selected value.

Down arrow key
Scrolls down through the display screen, and decreases a selected value.

STOP key
Issues a Stop command.



LED Display Guide

LED	ON	Flashing	OFF
ALM	A fault has occurred.	<ul style="list-style-type: none"> Alarm situation detected. Operator error (OPE) Auto-Tuning fault occurred. 	Normal operation
REV	Motor is rotating in reverse.	—	Motor is rotating forward.
DRV	<ul style="list-style-type: none"> In the "Drive Mode" Executing Auto-Tuning 	DriveWorksEZ is connected.	Programming Mode
FOUT	Output frequency	—	—
	Run command assigned to the operator (LOCAL)	—	Control assigned to remote location
	During run	<ul style="list-style-type: none"> During deceleration Run command is present but the frequency reference is zero. 	Drive is stopped.

How the RUN light works:

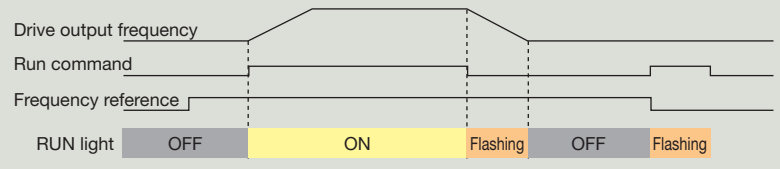

Operation Example

Using the LED Operator to Run the Drive

Steps	Key	Result/Display
1 Turn the power on.		F 000
2 Set the drive for LOCAL. The frequency reference is displayed.		LO should light. F 000
3 Displays the direction (forward).		For
4 Displays the output frequency.		000
5 Displays the output current.		000A
6 Displays the output voltage.		00V
7 Displays the beginning of the Monitor Menu.		flashing r7on
8 Displays the top of the Verify Menu.		flashing urF4
9 Displays the top of the Setup Mode.		flashing S7UP
10 Displays the top of the parameter settings menu.		PAR
11 Displays the top of the Auto-Tuning Mode.		Autn
Returns back to the frequency reference display.		F 000

Value will flash when it is possible to change the setting.

Drive Mode: Run and Stop commands, displays operation status such as the frequency reference, output frequency, output current, output voltage, etc.

How to Monitor the Frequency Reference

Steps	Key	Result/Display
Use the arrow keys to select the digits to set.		F00.00
		F00.00
Press enter to save the new value.		F06.00
		F06.00
		F06.00 "End" appears while the drive saves the new data. DRV DRV lights up.

Monitor Mode: Displays operation status and information on faults.

Steps	Key	Result/Display
Select a monitor.		U1-01
Displays U1-01, the frequency reference monitor.		6.00
Select another monitor.		U1-01
		U1-02
		U1-02
		U1-26
Back up to the top of the Monitor Menu.		r7on

Verify Menu: Lists all parameters that have been changed from their original default settings, either by the user or from Auto-Tuning.

Steps	Key	Result/Display
Lists parameters that have been changed in order.		C1-01
Pressing Enter displays the parameter value.		0003.0
		C1-01
		C1-02
		C1-02
		C6-02
Returns to the top of the Verify Menu.		urF4

Press to go back to the previous display screen.

Setup Mode

The list of Applications Presets can be accessed in the Setup Mode. Each Application Preset automatically programs drive parameters to their optimal settings specific to the application selected. All parameters affected by the Application Preset are then listed as Preferred Parameters for quick access.

Selecting a Water Supply Pump (A1-06=1)

Steps	Key	Result/Display
Application Selection		APPL
		00
		00
Select, "Water Supply Pump".		01
		APPL

All parameters relating to the preset values for a water supply pump application are then listed as Preferred Parameters.

Scroll to the Preferred Parameter using the up arrow key and see which parameters have been selected.

"End" appears while the drive saves the new data.

Water Supply Pump Application Presets

No.	Parameter Name	Optimum Setting
A1-02	Control Method Selection	0: V/f control
b1-04	Reverse Operation Selection	1: Reverse disabled
C1-01	Acceleration Time 1	1.0 (s)
C1-02	Deceleration Time 1	1.0 (s)
C6-01	Normal/Heavy Duty Selection	1: Normal Duty (ND)
E1-03	V/f Pattern Selection	0F (H)
E1-07	Mid Output Frequency	30.0 (Hz)
E1-08	Mid Output Frequency Voltage	50.0 (V)
L2-01	Momentary Power Loss Operation Selection	1: Enabled
L3-04	Stall Prevention Selection during Deceleration	1: Enabled

Preferred Parameters

No.	Parameter Name	No.	Parameter Name
b1-01	Frequency Reference Selection 1	E1-08	Mid Output Frequency Voltage (VC)
b1-02	Run Command Selection 1	E2-01	Motor Rated Current
b1-04	Reverse Operation Selection	H1-05	Multi-Function Digital Input Terminal S5 Function Selection
C1-01	Acceleration Time 1	H1-06	Multi-Function Digital Input Terminal S6 Function Selection
C1-02	Deceleration Time 1	H1-07	Multi-Function Digital Input Terminal S7 Function Selection
E1-03	V/f Pattern Selection	L5-01	Number of Auto Restart Attempts
E1-07	Mid Output Frequency	-	-

Product Lineup

Number in parenthesis indicates the rated output current.

Motor Capacity kW	Three-Phase 200 V		Single-Phase 200 V		Three-Phase 400 V	
	Normal Duty	Heavy Duty	Normal Duty	Heavy Duty	Normal Duty	Heavy Duty
0.1		CIMR-VA2A0001 (0.8 A)		CIMR-VABA0001 (0.8 A)		
0.2	CIMR-VA2A0001 (1.2 A)	CIMR-VA2A0002 (1.6 A)	CIMR-VABA0001 (1.2 A)	CIMR-VABA0002 (1.6 A)		CIMR-VA4A0001 (1.2 A)
0.4	CIMR-VA2A0002 (1.9 A)	CIMR-VA2A0004 (3 A)	CIMR-VABA0002 (1.9 A)	CIMR-VABA0003 (3 A)	CIMR-VA4A0001 (1.2 A)	CIMR-VA4A0002 (1.8 A)
0.75	CIMR-VA2A0004 (3.5 A)	CIMR-VA2A0006 (5 A)	CIMR-VABA0003 (3.3 A)	CIMR-VABA0006 (5 A)	CIMR-VA4A0002 (2.1 A)	CIMR-VA4A0004 (3.4 A)
1.1	CIMR-VA2A0006 (6 A)	CIMR-VA2A0008* (6.9 A)	CIMR-VABA0006 (6 A)			
1.5	CIMR-VA2A0008* (8 A)	CIMR-VA2A0010 (8 A)		CIMR-VABA0010 (8 A)	CIMR-VA4A0004 (4.1 A)	CIMR-VA4A0005 (4.8 A)
2.2	CIMR-VA2A0010 (9.6 A)	CIMR-VA2A0012 (11 A)	CIMR-VABA0010 (9.6 A)	CIMR-VABA0012 (11 A)	CIMR-VA4A0005 (5.4 A)	CIMR-VA4A0007 (5.5 A)
3.0	CIMR-VA2A0012 (12 A)	CIMR-VA2A0018* (14 A)	CIMR-VABA0012 (12 A)		CIMR-VA4A0007 (6.9 A)	CIMR-VA4A0009 (7.2 A)
3.7	CIMR-VA2A0018* (17.5 A)	CIMR-VA2A0020 (17.5 A)		CIMR-VABA0018 (17.5 A)	CIMR-VA4A0009 (8.8 A)	CIMR-VA4A0011 (9.2 A)
5.5	CIMR-VA2A0020 (19.6 A)	CIMR-VA2A0030 (25 A)			CIMR-VA4A0011 (11.1 A)	CIMR-VA4A0018 (14.8 A)
7.5	CIMR-VA2A0030 (30 A)	CIMR-VA2A0040 (33 A)			CIMR-VA4A0018 (17.5 A)	CIMR-VA4A0023 (18 A)
11	CIMR-VA2A0040 (40 A)	CIMR-VA2A0056 (47 A)			CIMR-VA4A0023 (23 A)	CIMR-VA4A0031 (24 A)
15	CIMR-VA2A0056 (56 A)	CIMR-VA2A0069 (60 A)			CIMR-VA4A0031 (31 A)	CIMR-VA4A0038 (31 A)
18.5	CIMR-VA2A0069 (69 A)				CIMR-VA4A0038 (38 A)	

*: Available in Japan only

Model Number Key

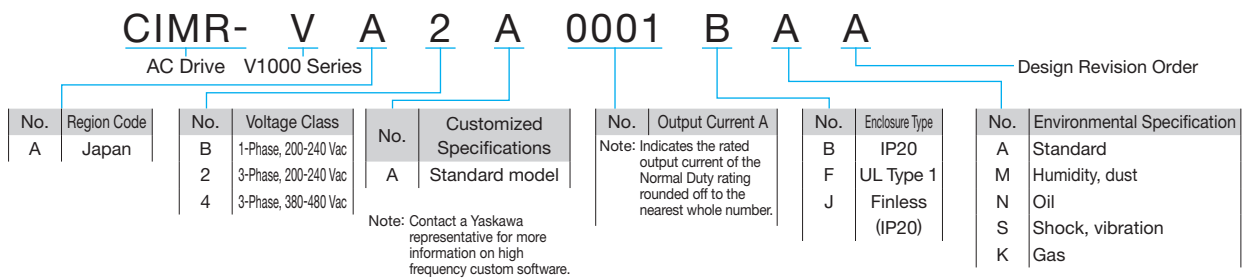

Optimizing Control for Each Application

V1000 offers two separate performance ratings: Normal Duty and Heavy Duty.

Heavy Duty is capable of creating more powerful torque, while Normal Duty allows the drive to operate a larger motor.

Difference between load ratings:

	Normal Duty Rating	Heavy Duty Rating
Parameter settings	C6-01 = 1 (default)	C6-01 = 0
Overload tolerance	120% for 60 s	150% for 60 s
Carrier frequency	Low carrier frequency (Swing PWM)*	High carrier frequency

*: Use Swing PWM to quiet undesirable motor noise generated when operating with a low carrier frequency.

Normal Duty Applications



Heavy Duty Applications

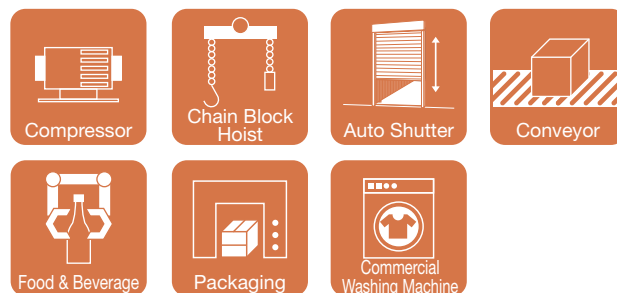

*The applications shown above can still use the ND rating, provided that the maximum torque required is no more than 120% for 60 s.

● Selecting a Drive

For a fan application using a 0.75 kW motor, select CIMR-VA2A0004 and set it for Normal Duty performance.

Model: CIMR-VA2A0004

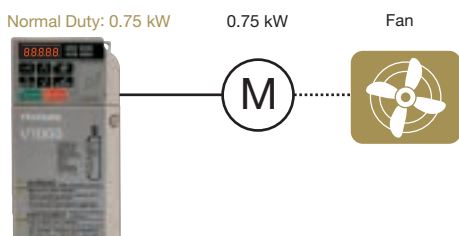

● Selecting a Drive

For a chain block application using a 0.75 kW motor, select CIMR-VA2A0006 and set it for Heavy Duty performance.

Model: CIMR-VA2A0006

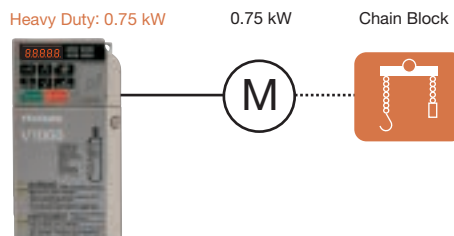

Use the table below to transition from VS mini V7 to the V1000 series (assumes a Heavy Duty rating).

Max. Applicable Motor Capacity kW	Power Supply Model	200 V				400 V	
		Three-Phase		Single-Phase		Three-Phase	
		VS mini V7 CIMR-V7AA2:□□□□	V1000 CIMR-VA2A:□□□□	VS mini V7 CIMR-V7AAB:□□□□	V1000 CIMR-VABA:□□□□	VS mini V7 CIMR-V7AA4:□□□□	V1000 CIMR-VA4A:□□□□
0.1		0P1	0001	0P1	0001	—	—
0.2		0P2	0002	0P2	0002	0P2	0001
0.4		0P4	0004	0P4	0003	0P4	0002
0.75		0P7	0006	0P7	0006	0P7	0004
1.5		1P5	0010	1P5	0010	1P5	0005
2.2		2P2	0012	2P2	0012	2P2	0007
3.7		3P7	0020	3P7	0018	3P7	0011
5.5		5P5	0030	—	—	5P5	0018
7.5		7P5	0040	—	—	7P5	0023
11		—	0056	—	—	—	0031
15		—	0069	—	—	—	0038

Standard Specifications

Parameter C6-01 sets the drive for Normal Duty or Heavy Duty performance.

200 V Class (Three-Phase/Single-Phase)

Value in brackets is for a single-phase drive.

Model	Three-Phase CIMR-VA2A	0001	0002	0004	0006	0008	0010	0012	0018	0020	0030	0040	0056	0069			
	Single-Phase*2 CIMR-VABA	0001	0002	0003	0006	—	0010	0012	—	0018*1	—	—	—	—			
Max. Applicable Motor Capacity*3	kW	Normal Duty	0.2	0.4	0.75	1.1	1.5	2.2	3.0	3.7	5.5	7.5	11.0	15.0	18.5		
		Heavy Duty	0.1	0.2	0.4	0.75	1.1	1.5	2.2	3.0	3.7	5.5	7.5	11.0	15.0		
Input	Rated Input Current	A	Three-phase	Normal Duty	1.1	1.9	3.9	7.3	8.8	10.8	13.9	18.5	24.0	37.0	52.0	80.0	
			Heavy Duty	0.7	1.5	2.9	5.8	7.0	7.5	11.0	15.6	18.9	24.0	37.0	52.0	68.0	
	Single-phase	Normal Duty	2.0	3.6	7.3	13.8	—	20.2	24.0	—	—	—	—	—	—		
		Heavy Duty	1.4	2.8	5.5	11.0	—	14.1	20.6	—	35.0	—	—	—	—		
Output	Rated Output Capacity*4	kVA	Normal Duty*5	0.5	0.7	1.3	2.3	3.0	3.7	4.6	6.7	7.5	11.4	15.2	21.3	26.3	
			Heavy Duty	0.3*6	0.6*6	1.1*6	1.9*6	2.6*7	3.0*7	4.2*7	5.3*7	6.7*7	9.5*7	12.6*7	17.9*7	22.9*7	
	Rated Output Current	A	Normal Duty*5	1.2	1.9	3.5 (3.3)	6.0	8.0	9.6	12.0	17.5	19.6	30.0	40.0	56.0	69.0	
			Heavy Duty	0.8*6	1.6*6	3.0*6	5.0*6	6.9*7	8.0*7	11.0*7	14.0*7	17.5*7	25.0*7	33.0*7	47.0*7	60.0*7	
	Overload Tolerance	Normal Duty Rating: 120% of rated output current for 60 s. Heavy Duty Rating: 150% of rated output current for 60 s. (Derating may be required for repetitive loads)															
	Carrier Frequency	2 kHz (user-set, 2 to 15 kHz possible)															
	Max. Output Voltage	Three-phase power supply: three-phase 200 to 240 V (relative to input voltage) Single-phase power supply: three-phase 200 to 240 V (relative to input voltage)															
	Max. Output Frequency	400 Hz (user-set)															
	Rated Voltage/Rated Frequency	Three-phase AC power supply: three-phase 200 to 240 V 50/60 Hz Single-phase AC power supply: single-phase 200 to 240 V 50/60 Hz DC power supply: 270 to 340 V*8															
	Allowable Voltage Fluctuation	-15 to +10%															
Allowable Frequency Fluctuation	±5%																
Power	Rated Voltage/Rated Frequency	kVA	Three-phase	Normal Duty	0.5	0.9	1.8	3.3	4.0	4.9	6.4	8.5	11.0	17.0	24.0	31.0	37.0
			Heavy Duty	0.3	0.7	1.3	2.7	3.2	3.4	5.0	7.1	8.6	11.0	17.0	24.0	31.0	
	Power Supply*9	kVA	Single-phase	Normal Duty	0.5	1.0	1.9	3.6	—	5.3	6.3	—	—	—	—	—	
			Heavy Duty	0.4	0.7	1.5	2.9	—	3.7	5.4	—	9.2	—	—	—	—	

*1: Heavy Duty (3.7 kW) only.

*2: Drives with a single-phase power supply input have three-phase output. Single-phase motors cannot be used.

*3: The motor capacity (kW) refers to a Yaskawa 4-pole, 60 Hz, 200 V motor. The rated output current of the drive output amps should be equal to or greater than the motor rated current.

*4: Rated output capacity is calculated with a rated output voltage of 220 V.

*5: This value assumes a carrier frequency of 2 kHz. Increasing the carrier frequency requires a reduction in current.

*6: This value assumes a carrier frequency of 10 kHz. Increasing the carrier frequency requires a reduction in current.

*7: This value assumes a carrier frequency of 8 kHz. Increasing the carrier frequency requires a reduction in current.

*8: Not compliant with the UL standards when using a DC power supply. To meet CE standards, fuses should be installed. For details, refer to page 37.

*9: Rated input capacity is calculated with a power line voltage of 240 V × 1.1.

400 V Class (Three-phase)

Model	CIMR-VA4A	0001	0002	0004	0005	0007	0009	0011	0018	0023	0031	0038		
Max. Applicable Motor Capacity*1	kW	Normal Duty	0.4	0.75	1.5	2.2	3.0	3.7	5.5	7.5	11.0	15.0	18.5	
		Heavy Duty	0.2	0.4	0.75	1.5	2.2	3.0	3.7	5.5	7.5	11.0	15.0	
Input	Rated Input Current	A	Normal Duty	1.2	2.1	4.3	5.9	8.1	9.4	14.0	20.0	24.0	38.0	44.0
			Heavy Duty	1.2	1.8	3.2	4.4	6.0	8.2	10.4	15.0	20.0	29.0	39.0
Output	Rated Output Capacity*2	kVA	Normal Duty*3	0.9	1.6	3.1	4.1	5.3	6.7	8.5	13.3	17.5	23.6	29.0
			Heavy Duty*4	0.9	1.4	2.6	3.7	4.2	5.5	7.0	11.3	13.7	18.3	23.6
	Rated Output Current	A	Normal Duty*3	1.2	2.1	4.1	5.4	6.9	8.8	11.1	17.5	23.0	31.0	38.0
			Heavy Duty*4	1.2	1.8	3.4	4.8	5.5	7.2	9.2	14.8	18.0	24.0	31.0
Overload Tolerance	Normal Duty Rating: 120% of rated output current for 60 s. Heavy Duty Rating: 150% of rated output current for 60 s. (Derating may be required for repetitive loads)													
Carrier Frequency	2 kHz (user-set, 2 to 15 kHz possible)													
Max. Output Voltage	Three-phase 380 to 480 V (relative to input voltage)													
Max. Output Frequency	400 Hz (user-set)													
Rated Voltage/Rated Frequency	Three-phase AC power supply 380 to 480 V 50/60 Hz DC power supply: 510 to 680 V*5													
Allowable Voltage Fluctuation	-15 to +10%													
Allowable Frequency Fluctuation	±5%													
Power	Power Supply*6	kVA	Normal Duty	1.1	1.9	3.9	5.4	7.4	8.6	13.0	18.0	22.0	35.0	40.0
			Heavy Duty	1.1	1.6	2.9	4.0	5.5	7.5	9.5	14.0	18.0	27.0	36.0

*1: The motor capacity (kW) refers to a Yaskawa 4-pole, 60 Hz, 400 V motor. The rated output current of the drive output amps should be equal to or greater than the motor rated current.

*2: Rated output capacity is calculated with a rated output voltage of 440 V.

*3: This value assumes a carrier frequency of 2 kHz. Increasing the carrier frequency requires a reduction in current.

*4: This value assumes a carrier frequency of 8 kHz. Increasing the carrier frequency requires a reduction in current.

*5: Not compliant with the UL standards when using a DC power supply. To meet CE standards, fuses should be installed. For details, refer to page 37.

*6: Rated input capacity is calculated with a power line voltage of 480 V × 1.1.

Common Specifications

Rotational Auto-Tuning must be performed to achieve the performance described with Open Loop Vector Control.

Item	Specifications	
Control Characteristics	Control Method	Open Loop Vector Control (Current Vector), V/f Control, PM Open Loop Vector Control (for SPM and IPM motors)
	Frequency Control Range	0.01 to 400 Hz
	Frequency Accuracy (Temperature Fluctuation)	Digital reference: within $\pm 0.01\%$ of the max. output frequency (-10 to $+50^{\circ}\text{C}$)
		Analog reference: within $\pm 0.1\%$ of the max. output frequency ($25 \pm 10^{\circ}\text{C}$)
	Frequency Setting Resolution	Digital reference: 0.01 Hz
		Analog reference: 1/1000 of max. frequency
	Output Frequency Resolution	20 bit of maximum output frequency (parameter E1-04 setting)
	Frequency Setting Signal	Main frequency reference: 0 to 10 Vdc (20 k Ω), 4 to 20 mA (250 Ω), 0 to 20 mA (250 Ω) Main speed reference : Pulse Train Input (max. 32 kHz)
	Starting Torque	200% / 0.5 Hz (assumes Heavy Duty rating IM of 3.7 kW or less using Open Loop Vector Control),* ¹ 50% / 6 Hz (assumes PM Open Loop Vector Control)
	Speed Control Range	1:100 (Open Loop Vector Control), 1:20 to 40 (V/f Control), 1:10 (PM Open Loop Vector Control)
	Speed Control Accuracy	$\pm 0.2\%$ in Open Loop Vector Control ($25 \pm 10^{\circ}\text{C}$) * ²
	Speed Response	5 Hz in Open Loop Vector ($25 \pm 10^{\circ}\text{C}$) (excludes temperature fluctuation when performing Rotational Auto-Tuning)
	Torque Limit	Open Loop Vector Control allows separate settings in four quadrants
	Accel/Decel Time	0.0 to 6000.0 s (4 selectable combinations of independent acceleration and deceleration settings)
Protection Function	Braking Torque	① Short-time decel torque* ³ : over 150% for 0.1/0.2 kW motors, over 100% for 0.4/ 0.75 kW motors, over 50% for 1.5 kW motors, and over 20% for 2.2 kW and above motors (overexcitation braking/High-Slip Braking: approx. 40%) ② Continuous regen. torque: approx. 20% (approx. 125% with dynamic braking resistor option* ⁴ : 10% ED, 10 s, internal braking transistor)
	V/f Characteristics	User-selected programs, V/f preset patterns possible
	Main Control Functions	Momentary power loss ride-thru, Speed search, Overtorque detection, Torque limit, 17-step speed (max), Accel/decel time switch, S-curve accel/decels, 3-wire sequence, Auto-tuning (rotational, stationary tuning for resistance between lines), Dwell, Cooling fan on/off switch, Slip compensation, Torque compensation, Frequency jump, Upper/lower limits for frequency reference, DC injection braking at start and stop, Overexcitation braking, High slip braking, PID control (with sleep function), Energy saving control, MEMOBUS/Modbus (RTU mode) comm. (RS-485/422 max, 115.2 kbps), Fault restart, Application presets, DriveWorksEZ (customized function), Removable terminal block with parameter backup function...
Operating Environment	Motor Protection	Motor overheat protection based on output current
	Momentary Overcurrent Protection	Drive stops when output current exceeds 200%* ⁵ of Heavy Duty Rating
	Overload Protection	Drive stops after 60 s at 150% of rated output current (Heavy Duty Rating)* ⁶
	Overvoltage Protection	200 V class: Stops when DC bus exceeds approx. 410 V
		400 V class: Stops when DC bus exceeds approx. 820 V (approx. 740 V when power supply voltage is less than 400 V)
	Undervoltage Protection	Three-phase 200 V class: Stops when DC bus falls below approx. 190 V
		Single-phase 200 V class: Stops when DC bus falls below approx. 160 V
		Three-phase 400 V class: Stops when DC bus falls below approx. 380 V (approx. 350 V when the power supply voltage is less than 400 V)
	Momentary Power Loss Ride-Thru	Stops after approx. 15 ms (default). Parameter settings allow the drive to continue running if power loss lasts for up to approx. 2 s * ⁷
	Heatsink Overheat Protection	Protection by thermistor
Braking Resistance Overheat Protection	Overheat sensor for braking resistor (optional ERF-type, 3% ED)	
Stall Prevention	Separate settings allowed during acceleration, and during run. Enable/disable only during deceleration.	
Standards Compliance	Ground Fault Protection	Protection by electronic circuit * ⁸
	Charge LED	Charge LED remains lit until DC bus has fallen below approx. 50 V
Protection Design	Area of Use	Indoors
	Ambient Temperature	-10 to $+50^{\circ}\text{C}$ (open chassis), -10 to $+40^{\circ}\text{C}$ (enclosure)
	Humidity	95 RH% or less (no condensation)
	Storage Temperature	-20 to $+60^{\circ}\text{C}$ (short-term temperature during transportation)
	Altitude	Up to 1000 meters
	Shock	10 to less than 20 Hz (9.8 m/s ²) max., 20 to 55 Hz (5.9 m/s ²) max.
Standards Compliance	<ul style="list-style-type: none"> ·UL508C ·IEC/EN61800-3, IEC/EN61800-5-1 ·ISO/EN13849-1 Cat.3 PLd, IEC/EN61508 SIL2 	
Protection Design	IP20 open-chassis, UL Type 1 enclosure	

*1: The capacity of the drive and motor must be considered to achieve this torque output.

*2: Speed control accuracy may vary slightly depending on installation conditions or motor used.

*3: Momentary average deceleration torque refers to the deceleration torque from 60Hz down to 0 Hz. This may vary depending on the motor.

*4: Disable Stall Prevention during deceleration by setting L3-04 (Stall Prevention Selection during Deceleration) to 0 (Disabled) when using a Braking Resistor or Braking Resistor Unit. The motor may not stop within the deceleration time if this setting is not changed from 1 (Enabled: default).

*5: 200% is the target value. The value varies depending on the capacity.

*6: Overload protection may be triggered at lower levels if output frequency is below 6 Hz.

*7: Varies by drive capacity. Drives smaller than 7.5 kW (CIMR-VA2A0040/ CIMR-VA4A0023) require a separate Momentary Power Loss Recovery Unit to continue operating during a momentary power loss of 2 s.

*8: Protection is provided when the motor is grounded during Run. Protection may not be provided under the following conditions:

- Low resistance to ground from the motor cable or terminal block.
- Drive already has a short-circuit when the power is turned on.



Standard Connection Diagram

Standard Connection Diagram

Example: 200 V Class

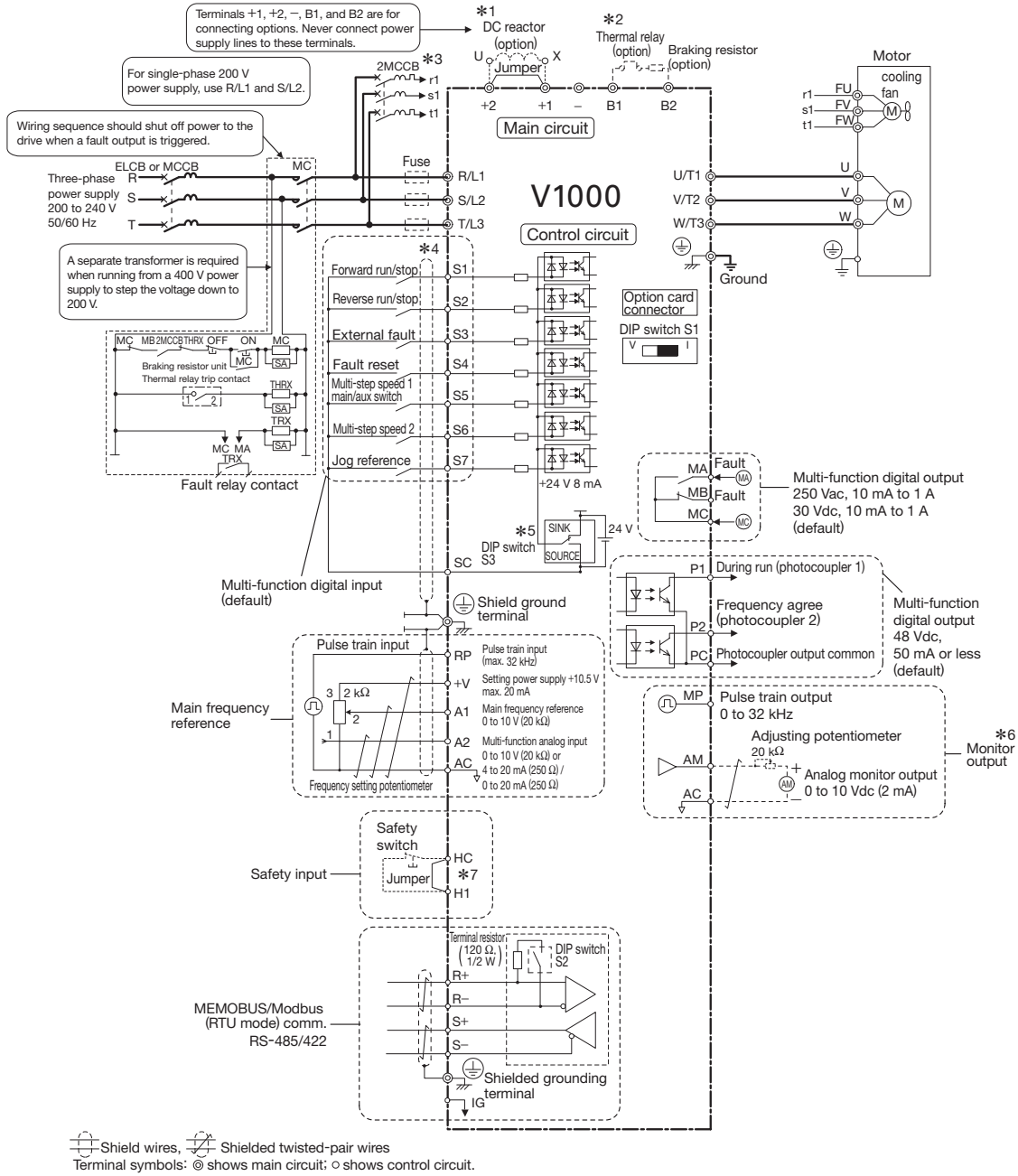

- *1: Remove the jumper between terminals +1 and +2 when installing an optional DC reactor.
 - *2: The MC on the input side of the main circuit should open when the thermal relay is triggered.
 - *3: Self-cooled motors do not require separate cooling fan motor wiring.
 - *4: Connected using sequence (0 V com/sink mode) input signal (S1 to S7) from NPN transistor (default).
 - *5: Sinking mode requires an internal 24 V power supply. Source mode requires an external power supply.
 - *6: Monitor outputs work with devices such as analog frequency meters, current meters, voltmeters and watt meters. They cannot be used in a control system requiring feedback.
 - *7: When using an external switch to stop the drive as a safety precaution, make sure the jumper creating the short circuit has been removed. Output is interrupted within 1 ms after the safety input is triggered. Make sure safety input wiring does not exceed 30 m.
- Note: Input terminal functions may change when Application Presets are used.

Control Circuit and Terminal Layout

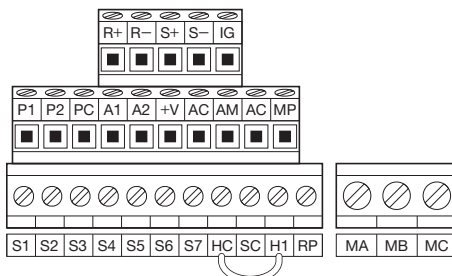

Terminal Functions

Main Circuit Terminals

Terminal	Terminal Name	Function (Signal Level)
R/L1	Main circuit power supply input	Connects line power to the drive. Drives with single-phase 200 V input power use terminals R/L1 and S/L2 only (do not use T/L3).
S/L2		
T/L3		
U/T1	Drive output	Connects to the motor.
V/T2		
W/T3		
B1	Braking resistor / Braking resistor unit	Available for connecting a braking resistor or braking resistor unit.
B2		
+1	DC reactor connection	These terminals are shorted for shipment. Remove the jumper creating the short to install a DC choke.
+2		
+1		
–	DC power supply input	For connecting a DC power supply. DC power supply input terminals (+1, –) are not UL/cUL and CE certified.
⊕ Two terminals		
Ground		Grounding terminal Grounding resistance for 200 V class: 100 Ω or less Grounding resistance for 400 V class: 10 Ω or less

Control Circuit Input Terminals

Terminal	No.	Terminal Name	Function (Signal Level)
Multi-function digital input	S1	Multi-function input 1	Photocoupler 24 Vdc, 8 mA Note: Drive preset to sinking mode. When using source mode, set DIP switch S3 to allow for a 24 Vdc (±10%) external power supply.
	S2	Multi-function input 2	
	S3	Multi-function input 3	
	S4	Multi-function input 4	
	S5	Multi-function input 5	
	S6	Multi-function input 6	
	S7	Multi-function input 7	
	SC	Multi-function input common (Control common)	
Main frequency reference input	RP	Multi-function pulse train input	Input frequency: 0.5 to 32 kHz (Duty cycle: 30 to 70%) (High level voltage: 3.5 to 13.2 V) (Low level voltage: 0.0 to 0.8 V) (Input impedance: 3 kΩ)
	+V	Analog input power supply	+10.5 V (max. allowable current 20 mA)
	A1	Main frequency reference	Input voltage 0 to 10 Vdc (20 kΩ) resolution: 1/1000
	A2	Multi-function analog input	DIP switch S1 sets the terminal for a voltage or current input signal 0 to 10 Vdc (20 kΩ) resolution: 1/1000 4 to 20 mA or 0 to 20 mA (250 Ω) resolution: 1/500
	AC	Frequency reference common	0 V
Hardwire baseblock	HC	Power supply for hardwire baseblock command	+24 Vdc (max. 10 mA allowed)
	H1	Safety Input	Open: Hardwire baseblock Closed: Normal operation
Multi-function digital output*1	MA	N.O. output	Digital output 30 Vdc (or less), 10 mA to 1 A 250 Vac (or less), 10 mA to 1 A
	MB	N.C. output	
	MC	Digital output common	
Multi-function photocoupler output	P1	Photocoupler output 1	Photocoupler output *2 48 Vdc (or less), 50 mA (or less)
	P2	Photocoupler output 2	
	PC	Photocoupler output common	
Monitor output	MP	Pulse train output	32 kHz (max.)
	AM	Analog monitor output	0 to 10 Vdc (2 mA or less) Resolution: 1/1000
	AC	Monitor common	0 V

*1: Refrain from assigning functions to terminals MA and MB that involve frequent switching, as doing so may shorten relay performance life. Switching life is estimated at 200,000 times (assumes 1 A, resistive load).

*2: Connect a flywheel diode as shown in the figure on the right when driving a reactive load such as a relay coil. Make sure the diode rating is greater than the circuit voltage.

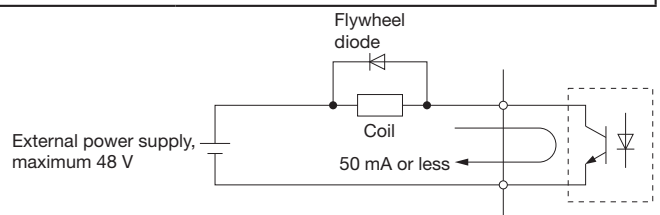

Serial Communication Terminals

Type	No.	Terminal Name	Function (Signal Level)
MEMOBUS/Modbus (RTU mode) communications	R+	Communications input (+)	MEMOBUS/Modbus (RTU mode) communications: · Use a RS-485 or RS-422 cable to connect the drive. · RS-485/422 MEMOBUS/Modbus (RTU mode) communications protocol 115.2 kbps (max.)
	R–	Communications input (–)	
	S+	Communications output (+)	
	S–	Communications output (–)	
	IG	Shielded ground	



Dimensions

Enclosures

Enclosures of standard products vary depending on the model. Refer to the table below.

200 V Class (Single/Three-Phase)

Model	Three-Phase CIMR-VA2A	0001	0002	0004	0006	0008	0010	0012	0018	0020	0030	0040	0056	0069
	Single-Phase CIMR-VABA	0001	0002	0003	0006	–	0010	0012	–	0018*	–	–	–	–
Max. Applicable Motor Capacity	Normal Duty	0.2	0.4	0.75	1.1	1.5	2.2	3	3.7	5.5	7.5	11	15	18.5
	Heavy Duty	0.1	0.2	0.4	0.75	1.1	1.5	2.2	3	3.7	5.5	7.5	11	15
Open-Chassis		Standard: IP20									IP00 (without top and bottom covers)			
Enclosure Panel [UL Type 1]		Option available (IP20 with UL Type 1 kit)									Standard			

400 V Class (Three-Phase)

Model	CIMR-VA4A	0001	0002	0004	0005	0007	0009	0011	0018	0023	0031	0038
Max. Applicable Motor Capacity	Normal Duty	0.4	0.75	1.5	2.2	3	3.7	5.5	7.5	11	15	18.5
	Heavy Duty	0.2	0.4	0.75	1.5	2.2	3	3.7	5.5	7.5	11	15
Open-Chassis		Standard: IP20							IP00 (without top and bottom covers)			
Enclosure Panel [UL Type 1]		Option available (IP20 with UL Type 1 kit)							Standard			

*: CIMR-VABA0018 does not have a Normal Duty rating

Open-Chassis [IP20]

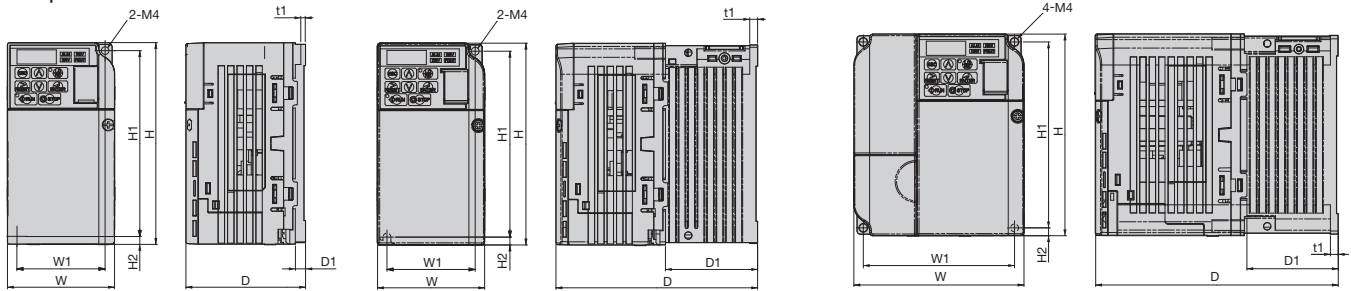

Figure 1

Figure 2

Figure 3

Voltage Class	Model CIMR- VA	Figure	Dimensions (mm)									Weight (kg)	Cooling	
			W	H	D	W1	H1	H2	D1	t1	Mtg. Holes			
200 V Class (Three-Phase)	2A0001B	1	68	128	76	56	118	5	6.5	3	M4	0.6	Self-cooled	
	2A0002B		68	128	76	56	118	5	6.5	3	M4	0.6		
	2A0004B	2	68	128	108	56	118	5	38.5	5	M4	0.9		
	2A0006B		68	128	128	56	118	5	58.5	5	M4	1.1		
	2A0008B	3	108	128	129	96	118	5	58	5	M4	1.7		Fan cooled
	2A0010B		108	128	129	96	118	5	58	5	M4	1.7		
	2A0012B		108	128	137.5	96	118	5	58	5	M4	1.7		
	2A0018B		140	128	143	128	118	5	65	5	M4	2.4		
2A0020B	140	128	143	128	118	5	65	5	M4	2.4				
200 V Class (Single-Phase)	BA0001B	1	68	128	76	56	118	5	6.5	3	M4	0.6	Self-cooled	
	BA0002B		68	128	76	56	118	5	6.5	3	M4	0.6		
	BA0003B	2	68	128	118	56	118	5	38.5	5	M4	1		
	BA0006B		108	128	137.5	96	118	5	58	5	M4	1.7		
	BA0010B	3	108	128	154	96	118	5	58	5	M4	1.8		Fan cooled
	BA0012B		140	128	163	128	118	5	65	5	M4	2.4		
	BA0018B		170	128	180	158	118	5	65	5	M4	3		
400 V Class (Three-Phase)	4A0001B	3	108	128	81	96	118	5	10	5	M4	1	Self-cooled	
	4A0002B		108	128	99	96	118	5	28	5	M4	1.2		
	4A0004B		108	128	137.5	96	118	5	58	5	M4	1.7		
	4A0005B		108	128	154	96	118	5	58	5	M4	1.7		
	4A0007B		108	128	154	96	118	5	58	5	M4	1.7	Fan cooled	
	4A0009B		108	128	154	96	118	5	58	5	M4	1.7		
	4A0011B		140	128	143	128	118	5	65	5	M4	2.4		

■ Enclosure Panel [UL Type 1]

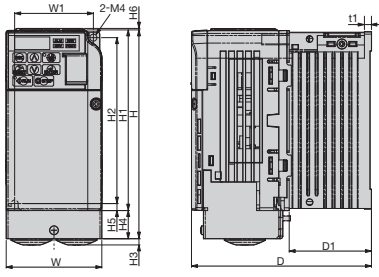

Figure 1

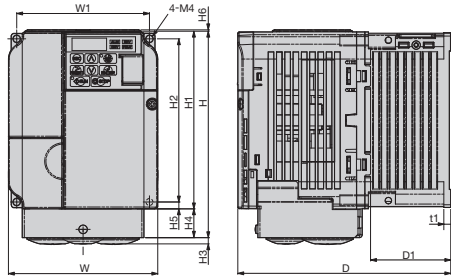

Figure 2

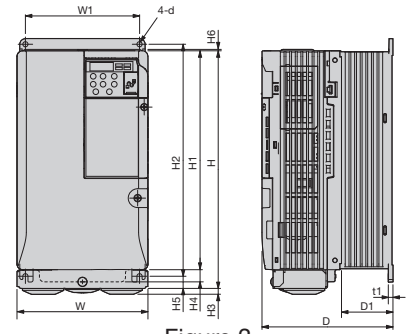

Figure 3

Voltage Class	Model CIMR-VA	Figure	Dimensions (mm)													Weight (kg)	UL Type 1 Kit Code No. (Model)	Cooling
			W1	H2	W	H1	D	t1	H5	D1	H	H4	H3	H6	d			
200 V Class (Three-Phase)	2A0001B	1	56	118	68	128	76	3	5	6.5	148	20	5	1.5	M4	0.8	100-036-378 (EZZ020564A)	Self cooled
	2A0002B		56	118	68	128	76	3	5	6.5	148	20	5	1.5	M4	0.8		
	2A0004B		56	118	68	128	108	5	5	38.5	148	20	5	1.5	M4	1.1		
	2A0006B		56	118	68	128	128	5	5	58.5	148	20	5	1.5	M4	1.3		
	2A0008B	2	96	118	108	128	129	5	5	58	149	21	5	1.5	M4	1.9	100-036-380 (EZZ020564G)	Fan cooled
	2A0010B		96	118	108	128	129	5	5	58	149	21	5	1.5	M4	1.9		
	2A0012B		96	118	108	128	137.5	5	5	58	149	21	5	1.5	M4	1.9		
	2A0018B		128	118	140	128	143	5	5	65	149	21	5	5	M4	2.6		
	2A0020B		128	118	140	128	143	5	5	65	149	21	5	5	M4	2.6		
	2A0030F		3	122	248	140	234	140	5	13	55	254	13	6	1.5	M5		
2A0040F	122	248		140	234	140	5	13	55	254	13	6	1.5	M5	3.8			
2A0056F	160	284		180	270	163	5	13	75	290	15	6	1.5	M5	5.5			
2A0069F	192	336		220	320	187	5	22	78	350	15	7	1.5	M6	9.2			
200 V Class (Single-Phase)	BA0001B	1	56	118	68	128	76	3	5	6.5	148	20	5	1.5	M4	0.8	100-036-378 (EZZ020564A)	Self cooled
	BA0002B		56	118	68	128	76	3	5	6.5	148	20	5	1.5	M4	0.8		
	BA0003B		56	118	68	128	118	5	5	38.5	148	20	5	1.5	M4	1.2		
	BA0006B	2	96	118	108	128	137.5	5	5	58	149	21	5	1.5	M4	1.9	100-036-381 (EZZ020564C)	Fan cooled
	BA0010B		96	118	108	128	154	5	5	58	149	21	5	1.5	M4	2		
	BA0012B		128	118	140	128	163	5	5	65	149	21	5	5	M4	2.6		
BA0018B	158	118	170	128	180	5	5	65	166	38	5	5	M4	3.3	100-036-386 (EZZ020564F)			
400 V Class (Three-Phase)	4A0001B	2	96	118	108	128	81	5	5	10	149	21	5	1.5	M4	1.2	100-036-380 (EZZ020564G)	Self cooled
	4A0002B		96	118	108	128	99	5	5	28	149	21	5	1.5	M4	1.4		
	4A0004B		96	118	108	128	137.5	5	5	58	149	21	5	1.5	M4	1.9		
	4A0005B		96	118	108	128	154	5	5	58	149	21	5	1.5	M4	1.9		
	4A0007B		96	118	108	128	154	5	5	58	149	21	5	1.5	M4	1.9		
	4A0009B		96	118	108	128	154	5	5	58	149	21	5	1.5	M4	1.9		
	4A0011B	3	128	118	140	128	143	5	5	65	149	21	5	5	M4	2.6	100-036-384 (EZZ020564H)	Fan cooled
	4A0018F		122	248	140	234	140	5	13	55	254	13	6	1.5	M5	3.8		
	4A0023F		122	248	140	234	140	5	13	55	254	13	6	1.5	M5	3.8		
	4A0031F		160	284	180	270	143	5	13	55	290	15	6	1.5	M5	5.2		
4A0038F	160	284	180	270	163	5	13	75	290	15	6	1.5	M5	5.5				

Note: For the models shown in Figures 1 and 2, the UL Type 1 kit (option) is required.
The dimensions in the above table are intended for the IP20/Open Chassis enclosure with the UL Type 1 kit.

Fully-Enclosed Design and Watt Loss Data

The Open Chassis type drive can be installed in a fully-enclosed panel.

An open chassis model in a protective enclosure with the heatsink inside the panel allows for intake air temperature up to 50°C. The heatsink can alternatively be mounted outside the control panel, thus reducing the amount of heat inside the panel and allowing for a more compact set up. Be sure to leave enough clearance during installation for ventilation and proper cooling as well as access to wiring for maintenance.

Cooling Design for Fully-Closed Enclosure Panel

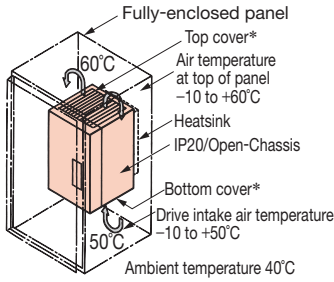

Mounting the External Heatsink

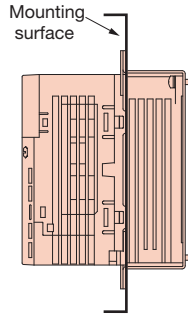

Ensuring Ventilation

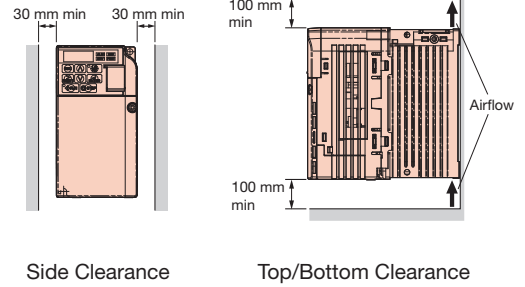

*: The Enclosure Panel type models (CIMR-VA2A0030 to 0069, CIMR-VA4A0018 to 0038) can be installed with the top and bottom covers removed.

Note: An attachment (option) is required to install the heatsink outside the enclosure. Refer to the following page.
Heatsink side: 35°C
Open chassis side: 35°C

Drive Watt Loss Data

Normal Duty Ratings

Voltage Class	Model Number		0001	0002	0004	0006	0008	0010	0012	0018	0020	0030	0040	0056	0069		
200 V Class (Three-Phase)	CIMR-VA2A ¹	Rated Output Current	A	1.2	1.9	3.5	6	8	9.6	12	17.5	19.6	30	40	56	69	
		Watt Loss	Heatsink	W	5	7.6	15.8	27.5	44.6	51.7	61.3	89.8	98.7	246.4	266.7	357.9	461.7
			Internal	W	8	9.5	13.6	17.2	24	25.8	30.4	44.1	46.3	88.9	112.8	151.8	184.5
			Total Watt Loss	W	13	17.1	29.4	44.7	68.6	77.5	91.7	133.9	145	335.3	379.5	509.7	646.2
200 V Class (Single-Phase)	CIMR-VABA ¹	Rated Output Current	A	1.2	1.9	3.3	6	—	9.6	12	—	—	—	—	—	—	
		Watt Loss	Heatsink	W	5	7.6	14.6	30.1	—	51.7	61.3	—	—	—	—	—	—
			Internal	W	8.5	9.7	14.4	19.4	—	29.8	37.1	—	—	—	—	—	—
			Total Watt Loss	W	13.5	17.3	29	49.5	—	81.5	98.4	—	—	—	—	—	—
400 V Class (Three-Phase)	CIMR-VA4A ¹	Rated Output Current	A	1.2	2.1	4.1	5.4	—	6.9	8.8	—	11.1	17.5	23	31	38	
		Watt Loss	Heatsink	W	10	18.5	30.5	44.5	—	58.5	63.7	—	81.7	181.2	213.4	287.5	319.2
			Internal	W	9.6	13.9	16.8	21.8	—	28.5	31.4	—	46	80.1	107.7	146.1	155.8
			Total Watt Loss	W	19.6	32.4	47.3	66.3	—	87	95.1	—	127.7	261.3	321.1	433.6	475

Note: Watt loss data based on carrier frequency of 2 kHz (default).

Heavy Duty Ratings

Voltage Class	Model Number		0001*1	0002*1	0004*1	0006*1	0008*1	0010*2	0012*2	0018*2	0020*2	0030*2	0040*2	0056*2	0069*2		
200 V Class (Three-Phase)	CIMR-VA2A ¹	Rated Output Current	A	0.8	1.6	3	5	6.9	8	11	14	17.5	25	33	47	60	
		Watt Loss	Heatsink	W	4.3	7.9	16.1	27.4	48.7	54.8	70.7	92.6	110.5	231.5	239.5	347.6	437.7
			Internal	W	7.3	8.8	11.5	15.9	22.2	23.8	30	38.8	43.3	72.2	81.8	117.6	151.4
			Total Watt Loss	W	11.6	16.7	27.6	43.3	70.9	78.6	100.7	131.4	153.8	303.7	321.3	465.2	589.1
200 V Class (Single-Phase)	CIMR-VABA ¹	Rated Output Current	A	0.8	1.6	3	5	—	8	11	—	17.5	—	—	—	—	
		Watt Loss	Heatsink	W	4.3	7.9	16.1	33.7	—	54.8	70.7	—	110.5	—	—	—	—
			Internal	W	7.4	8.9	11.5	16.8	—	25.9	34.1	—	51.4	—	—	—	—
			Total Watt Loss	W	11.7	16.8	27.6	50.5	—	80.7	104.8	—	161.9	—	—	—	—
400 V Class (Three-Phase)	CIMR-VA4A ¹	Rated Output Current	A	1.2	1.8	3.4	4.8	—	5.5	7.2	—	9.2	14.8	18	24	31	
		Watt Loss	Heatsink	W	19.2	28.9	42.3	70.7	—	81	84.6	—	107.2	166	207.1	266.9	319.1
			Internal	W	11.4	14.9	17.9	26.2	—	30.7	32.9	—	41.5	62.7	78.1	105.9	126.6
			Total Watt Loss	W	30.6	43.8	60.2	96.9	—	111.7	117.5	—	148.7	228.7	285.2	372.8	445.7

*1: Watt loss data based on carrier frequency of 10 kHz (default).

*2: Watt loss data based on carrier frequency of 8 kHz (default).

Attachment for External Heatsink

Additional attachments required for installation.
Final dimensions are taller than drive height.

Dimensions (Heatsink for a 200 V 0.4 kW drive)

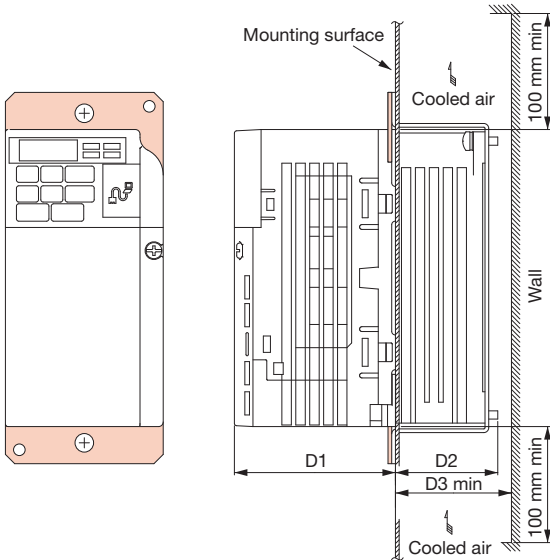

Note: The Enclosure Panel type models (CIMR-VA2A0030 to 0069, CIMR-VA4A0018 to 0038) can be installed with the top and bottom covers removed.

Model CIMR-VA:	Dimensions (mm)			Code No. (Model)
	D1	D2	D3	
2A0001	69.5	12	30	100-034-075 (EZZ020568A)
2A0002				
2A0004				
2A0006	71	62	70	100-034-076 (EZZ020568B)
2A0008		58	70	100-034-077 (EZZ020568G)
2A0010				
2A0012	79.5	65	70	100-034-079 (EZZ020568D)
2A0018				
2A0020				
2A0030	86.6	53.4	60	100-034-080 (EZZ020568E)
2A0040				
2A0056				
2A0069	89.6	73.4	80	100-036-300 (EZZ020568H)
	110.6	76.4	85	100-036-301 (EZZ020568J)
	100-036-302 (EZZ020568K)			
BA0001	69.5	12	30	100-034-075 (EZZ020568A)
BA0002	69.5	42	50	100-034-076 (EZZ020568B)
BA0003	69.5	42	50	100-034-076 (EZZ020568B)
BA0006	79.5	58	70	100-036-418 (EZZ020568C)
BA0010	96	58	70	100-036-418 (EZZ020568C)
BA0012	98	65	70	100-034-079 (EZZ020568D)
BA0018	115	65	70	100-034-080 (EZZ020568E)
BA0018	115	65	70	100-036-357 (EZZ020568F)
4A0001	71	13.5	30	100-036-418 (EZZ020568C)
4A0002	71	28	40	100-034-078 (EZZ020568L)
4A0004	79.5	58	70	100-036-418 (EZZ020568C)
4A0005	96	58	70	100-034-079 (EZZ020568D)
4A0007				
4A0009				
4A0011	78	65	70	100-034-080 (EZZ020568E)
4A0018	86.6	53.4	60	100-034-080 (EZZ020568E)
4A0023				
4A0031				
4A0038	89.6	53.4	60	100-036-300 (EZZ020568H)
		73.4	80	100-036-301 (EZZ020568J)

DIN rail attachment available for quick mounting and disassembly.

DIN Rail Attachment

The attachment is applicable to models with dimensions of 170 mm (W) and 128 mm (H) max.
Not for use with finless-type models (models without a heatsink).

Dimension (Heatsink for a 200 V 0.4 kW drive)

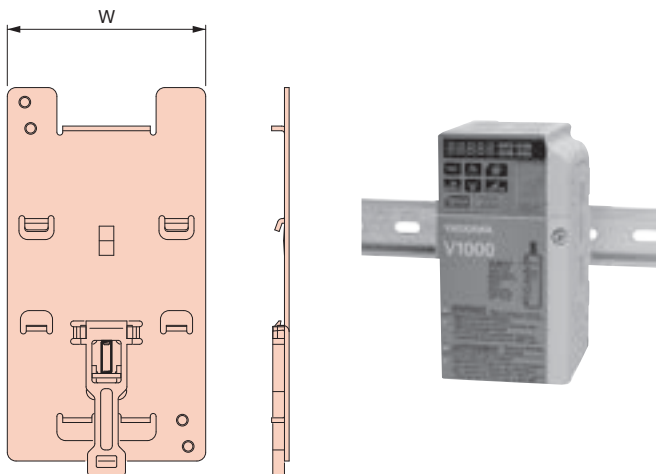

Model CIMR-VA:	Width (mm)	Code No.
2A0001	68	EZZ08122A
2A0002		
2A0004		
2A0006	108	EZZ08122B
2A0008		
2A0010		
2A0012	140	EZZ08122C
2A0018		
2A0020		
BA0001	68	EZZ08122A
BA0002		
BA0003		
BA0006	108	EZZ08122B
BA0010		
BA0012		
BA0018	170	EZZ08122D
BA0018		
BA0018		
4A0001	108	EZZ08122B
4A0002		
4A0004		
4A0005		
4A0007		
4A0009		
4A0011		
4A0011	140	EZZ08122C



Peripheral Devices and Options

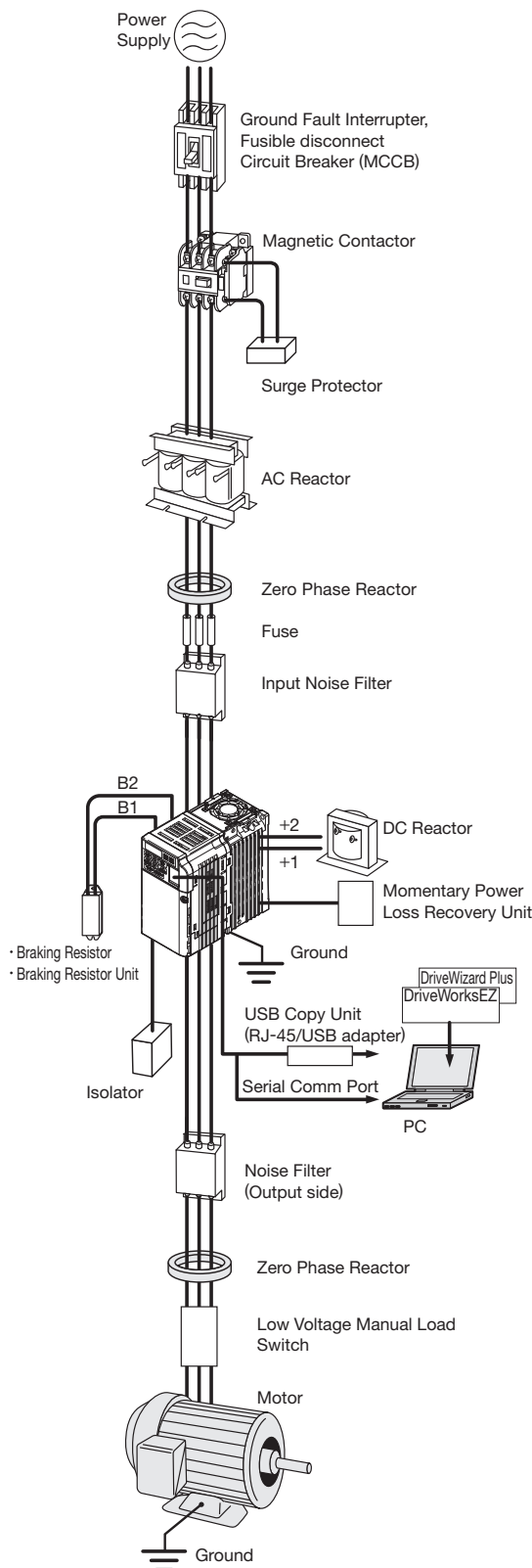

Name	Purpose	Model, Manufacturer	Page
Ground Fault Interrupter (GFI)	Always install a GFI on the power-supply side to protect the power supply system and to prevent an overload at the occurrence of short-circuit, and to protect the drive from ground faults that could result in electric shock or fire. Note: When a GFI is installed for the upper power supply system, an MCCB can be used instead of a GFI. (Choose a GFI designed to minimize harmonics specifically for AC drives. Use one GFI per drive, each with a current rating of at least 30 mA.)	Recommended: NV series by Mitsubishi Electric	p.30
Circuit Breaker	Always install a circuit breaker on the power-supply side to protect the power supply system and to prevent an overload at the occurrence of a short-circuit.	Recommended: NF series by Mitsubishi Electric	p.30
Magnetic Contactor	Interrupts the power supply to the drive. In addition to protecting drive circuitry, a magnetic contactor also prevents damage to a braking resistor if used.	Recommended: SC series by Fuji Electric	p.31
Surge Protector	Absorbs the voltage surge from switching of electro-magnetic contactors and control relays. Install a surge protector to the magnetic contactors and control relays as well as magnetic valves and magnetic braking coil.	DCR2 series RFN series by Nippon Chemi-Con Corporation	p.31
DC Reactor	Used for harmonic current suppression and total improving power factor.	UZDA series	p.32, 33
AC Reactor	Should be used if the power supply capacity is larger than 600 kVA.	UZBA series	p.34, 35
Zero Phase Reactor	Reduces noise from the line that enters into the drive input power system. Should be installed as close as possible to the drive. Can be used on both the input and output sides.	F6045GB F11080GB by Hitachi Metals, Ltd.	p.36
Fuse / Fuse Holder	Protects internal circuitry in the event of component failure. Fuse should be connected to the input terminal of the drive. Note: Refer to the instruction manual for information on UL approval.	CR6L series CMS series by Fuji Electric	p.37
Capacitor-type Noise Filter	Reduces noise from the line that enters into the drive input power system. The noise filter can be used in combination with a zero-phase reactor. Note: Available for drive input only. Do not connect the noise filter to the output terminals.	3XYG 1003 by Okaya Electric Industries	p.37
Input Noise Filter	Reduces noise from the line that enters into the drive input power system. Should be installed as close as possible to the drive.	LNFD series LNFB series FN series For CE Marking (EMC Directive) compliant models, refer to V1000 Technical Manual.	p.38, 39
Output Noise Filter	Reduces noise from the line that enters into the drive input power system. Should be installed as close as possible to the drive.	LF series by NEC TOKIN Corporation	p.40
Isolator	Isolates the drive I/O signal, and is effective in reducing inductive noise.	DGP2 series	p.41
Braking Resistor	Used to shorten the deceleration time by dissipating regenerative energy through a resistor. (3% ED)	ERF150WJ series CF120-B579 series	p.42, 43
Braking Resistor Unit	Used to shorten the deceleration time by dissipating regenerative energy through a resistor. A thermal overload relay is built in. (10% ED)	LKEB series	p.42, 43
24 V Power Supply	Provides power supply for the control circuit and option boards. Note: Parameter settings cannot be changed when the drive is operating solely from this power supply.	PS-V10S PS-V10M	p.44
USB Copy Unit (RJ-45/USB compatible plug)	· Adapter for connecting the drive to the USB port of a PC. · Can copy parameter settings to be later transferred to another drive.	JVOP-181	p.45

Name	Purpose	Model, Manufacturer	Page	
Support Tools (DriveWizard) Cable	Connects the drive to a PC for use with DriveWizard.	WV103	p.45	
Remote Digital Operator	Allows for remote operation. Includes a Copy function for saving drive settings.	LCD: JVOP-180 LED: JVOP-182	p.46	
Operator Extension Cable	Cable for connecting the remote digital operator.	WV001: 1 m WV003: 3 m		
Communication Interface Unit	Allows control of the drive via a fieldbus network.	MECHATROLINK-II	SI-T3/V	p.47
		MECHATROLINK-III	SI-ET3/V*1	
		CC-Link	SI-C3/V	
		DeviceNet	SI-N3/V	
		CompoNet	SI-M3/V	
		PROFIBUS-DP	SI-P3/V	
		CANopen	SI-S3/V	
		EtherCAT	SI-ES3/V	
		EtherNet/IP	SI-EN3/V	
		Modbus/TCP	SI-EM3/V	
PROFINET	SI-EP3/V			
Momentary Power Loss Recovery Unit	Ensures continued drive operation for a power loss of up to 2 s.	P0010 (200 V class) P0020 (400 V class)	p.48	
Frequency Meter, Current Meter	Allows the user to set and monitor the frequency, current, and voltage using an external device.	DCF-6A	p.48	
Frequency setting Potentiometer (2 k Ω)		RH000739		
Frequency Meter Adjusting Potentiometer (20 k Ω)		RH000850		
Control Dial for Frequency Setting Potentiometer		CM-3S*2	p.49	
Output Voltage Meter		SCF-12NH		
Potential Transformer		UPN-B		
UL Type 1 Kit	Turns an IP20 open-chassis design into a UL Type 1 compliant enclosure panel.	–	p.25	
Attachment for External Heatsink	Mechanical kit to install the drive with the heatsink out of the cabinet. Note: Current derating must be considered in some instances.	–	p.27	
DIN Rail Attachment	Allows mounting the drive on a DIN rail. Installs to the rear of the drive unit.	–		
Low Voltage Manual Load Switch	Prevents shock from the voltage created on the terminals board from a coasting synchronous motor.	Recommended: AICUT, LB series by AICHI ELECTRIC WORKS CO.,Ltd.	–	

*1: MECHATROLINK-III SI-ET3/V is available in drive software versions PRG: S1023 and later.

*2: Switch to replacement product K-2901-M after stock runs out.

Note: Contact the manufacturer in question for availability and specifications of non-Yaskawa products.



Ground Fault Interrupter, Circuit Breaker

Base device selection on motor capacity. Make sure that the rated breaking capacity is higher than the shortcircuit current for the power supply. Protect the wiring to withstand the short-circuit current for the power supply using a combination of fuses if the rated breaking capacity of the circuit breaker or ground fault interrupter is insufficient, such as when the power transformer capacity is large.



Ground Fault Interrupter
[Mitsubishi Electric]



Circuit Breaker
[Mitsubishi Electric]

Three-Phase 200 V Class

Motor Capacity (kW)	Ground Fault Interrupter						Circuit Breaker					
	Without Reactor*1			With Reactor*2			Without Reactor*1			With Reactor*2		
	Model	Rated Current (A)	Interrupt Capacity (kA) Icu/Ics*3	Model	Rated Current (A)	Interrupt Capacity (kA) Icu/Ics*3	Model	Rated Current (A)	Interrupt Capacity (kA) Icu/Ics*3	Model	Rated Current (A)	Interrupt Capacity (kA) Icu/Ics*3
0.1	NV32-SV	5	10/10	NV32-SV	5	10/10	NF32-SV	5	7.5/7.5	NF32-SV	5	7.5/7.5
0.2	NV32-SV	5	10/10	NV32-SV	5	10/10	NF32-SV	5	7.5/7.5	NF32-SV	5	7.5/7.5
0.4	NV32-SV	5	10/10	NV32-SV	5	10/10	NF32-SV	5	7.5/7.5	NF32-SV	5	7.5/7.5
0.75	NV32-SV	10	10/10	NV32-SV	10	10/10	NF32-SV	10	7.5/7.5	NF32-SV	10	7.5/7.5
1.5	NV32-SV	15	10/10	NV32-SV	10	10/10	NF32-SV	15	7.5/7.5	NF32-SV	10	7.5/7.5
2.2	NV32-SV	20	10/10	NV32-SV	15	10/10	NF32-SV	20	7.5/7.5	NF32-SV	15	7.5/7.5
3.7	NV32-SV	30	10/10	NV32-SV	20	10/10	NF32-SV	30	7.5/7.5	NF32-SV	20	7.5/7.5
5.5	NV63-SV	50	15/15	NV63-SV	40	15/15	NF63-SV	50	15/15	NF63-SV	40	15/15
7.5	NV125-SV	60	50/50	NV63-SV	50	15/15	NF125-SV	60	50/50	NF63-SV	50	15/15
11	NV125-SV	75	50/50	NV125-SV	75	50/50	NF125-SV	75	50/50	NF125-SV	75	50/50
15	NV250-SV	125	85/85	NV125-SV	100	50/50	NF250-SV	125	85/85	NF125-SV	100	50/50
18.5	NV250-SV	150	85/85	NV250-SV	125	85/85	NF250-SV	150	85/85	NF250-SV	125	85/85

Single-Phase 200 V Class

Motor Capacity (kW)	Ground Fault Interrupter						Circuit Breaker					
	Without Reactor*1			With Reactor*2			Without Reactor*1			With Reactor*2		
	Model	Rated Current (A)	Interrupt Capacity (kA) Icu/Ics*3	Model	Rated Current (A)	Interrupt Capacity (kA) Icu/Ics*3	Model	Rated Current (A)	Interrupt Capacity (kA) Icu/Ics*3	Model	Rated Current (A)	Interrupt Capacity (kA) Icu/Ics*3
0.1	NV32-SV	5	10/10	NV32-SV	5	10/10	NF32-SV	5	7.5/7.5	NF32-SV	5	7.5/7.5
0.2	NV32-SV	5	10/10	NV32-SV	5	10/10	NF32-SV	5	7.5/7.5	NF32-SV	5	7.5/7.5
0.4	NV32-SV	10	10/10	NV32-SV	10	10/10	NF32-SV	10	7.5/7.5	NF32-SV	10	7.5/7.5
0.75	NV32-SV	20	10/10	NV32-SV	15	10/10	NF32-SV	20	7.5/7.5	NF32-SV	15	7.5/7.5
1.5	NV32-SV	30	10/10	NV32-SV	20	10/10	NF32-SV	30	7.5/7.5	NF32-SV	20	7.5/7.5
2.2	NV32-SV	30	10/10	NV32-SV	20	10/10	NF32-SV	30	7.5/7.5	NF32-SV	20	7.5/7.5
3.7	NV63-SV	50	15/15	NV63-SV	40	15/15	NF63-SV	50	15/15	NF63-SV	40	15/15

Three-Phase 400 V Class

Motor Capacity (kW)	Ground Fault Interrupter						Circuit Breaker					
	Without Reactor*1			With Reactor*2			Without Reactor*1			With Reactor*2		
	Model	Rated Current (A)	Interrupt Capacity (kA) Icu/Ics*3	Model	Rated Current (A)	Interrupt Capacity (kA) Icu/Ics*3	Model	Rated Current (A)	Interrupt Capacity (kA) Icu/Ics*3	Model	Rated Current (A)	Interrupt Capacity (kA) Icu/Ics*3
0.2	NV32-SV	5	5/5	NV32-SV	5	5/5	NF32-SV	3	2.5/2.5	NF32-SV	3	2.5/2.5
0.4	NV32-SV	5	5/5	NV32-SV	5	5/5	NF32-SV	3	2.5/2.5	NF32-SV	3	2.5/2.5
0.75	NV32-SV	5	5/5	NV32-SV	5	5/5	NF32-SV	5	2.5/2.5	NF32-SV	5	2.5/2.5
1.5	NV32-SV	10	5/5	NV32-SV	10	5/5	NF32-SV	10	2.5/2.5	NF32-SV	10	2.5/2.5
2.2	NV32-SV	15	5/5	NV32-SV	10	5/5	NF32-SV	15	2.5/2.5	NF32-SV	10	2.5/2.5
3.7	NV32-SV	20	5/5	NV32-SV	15	5/5	NF32-SV	20	2.5/2.5	NF32-SV	15	2.5/2.5
5.5	NV32-SV	30	5/5	NV32-SV	20	5/5	NF32-SV	30	2.5/2.5	NF32-SV	20	2.5/2.5
7.5	NV32-SV	30	5/5	NV32-SV	30	5/5	NF32-SV	30	2.5/2.5	NF32-SV	30	2.5/2.5
11	NV63-SV	50	7.5/7.5	NV63-SV	40	7.5/7.5	NF63-SV	50	7.5/7.5	NF63-SV	40	7.5/7.5
15	NV125-SV	60	25/25	NV63-SV	50	7.5/7.5	NF125-SV	60	25/25	NF63-SV	50	7.5/7.5
18.5	NV125-SV	75	25/25	NV125-SV	60	25/25	NF125-SV	75	25/25	NF125-SV	60	25/25

*1 : The AC or DC reactor is not connected to the drive.

*2 : The AC or DC reactor is connected to the drive.

*3 : Icu: Rated ultimate short-circuit breaking capacity Ics: Rated service short-circuit breaking capacity

Magnetic Contactor

Base device selection on motor capacity.

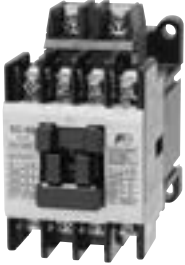

Magnetic Contactor
[Fuji Electric]

Motor Capacity (kW)	Three-Phase 200 V Class				Single-Phase 200 V Class				Three-Phase 400 V Class			
	Without Reactor*1		With Reactor*2		Without Reactor*1		With Reactor*2		Without Reactor*1		With Reactor*2	
	Model	Rated Current (A)	Model	Rated Current (A)	Model	Rated Current (A)	Model	Rated Current (A)	Model	Rated Current (A)	Model	Rated Current (A)
0.1	SC-03	11	SC-03	11	SC-03	11	SC-03	11	—	—	—	—
0.2	SC-03	11	SC-03	11	SC-03	11	SC-03	11	SC-03	7	SC-03	7
0.4	SC-03	11	SC-03	11	SC-03	11	SC-03	11	SC-03	7	SC-03	7
0.75	SC-05	13	SC-03	11	SC-4-0	18	SC-4-0	18	SC-03	7	SC-03	7
1.5	SC-4-0	18	SC-05	13	SC-N2	35	SC-N1	26	SC-05	9	SC-05	9
2.2	SC-N1	26	SC-4-0	18	SC-N2	35	SC-N2	35	SC-4-0	13	SC-4-0	13
3.7	SC-N2	35	SC-N1	26	SC-N2S	50	SC-N2S	50	SC-4-1	17	SC-4-1	17
5.5	SC-N2S	50	SC-N2	35	—	—	—	—	SC-N2	32	SC-N1	25
7.5	SC-N3	65	SC-N2S	50	—	—	—	—	SC-N2S	48	SC-N2	32
11	SC-N4	80	SC-N4	80	—	—	—	—	SC-N2S	48	SC-N2S	48
15	SC-N5	93	SC-N4	80	—	—	—	—	SC-N3	65	SC-N2S	48
18.5	SC-N5	93	SC-N5	93	—	—	—	—	SC-N3	65	SC-N3	65

*1 : The AC or DC reactor is not connected to the drive.

*2 : The AC or DC reactor is connected to the drive.

Surge Protector

Dimensions (mm)

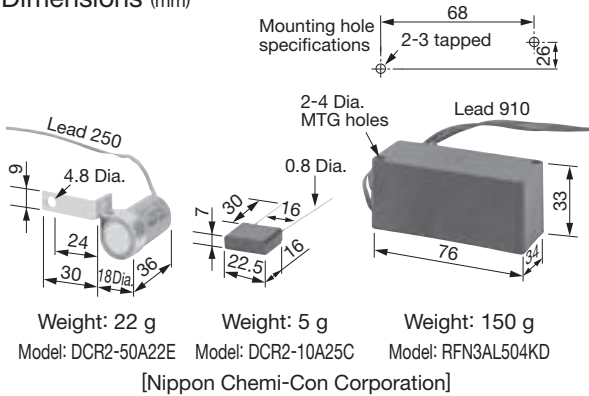

Product Line

Surge Protector		Model	Specifications	Code No.
200 V to 230 V	Large-Capacity Coil (other than relay)	DCR2-50A22E	220 Vac 0.5 μ F+200 Ω	100-250-545
200 V to 240 V	Control Relay	MY2, MY3 [Omron Corporation] MM2, MM4 [Omron Corporation] HH22, HH23 [Fuji Electric]	250 Vac 0.1 μ F+100 Ω	100-250-546
380 to 480 V		RFN3AL504KD	1000 Vdc 0.5 μ F+220 Ω	100-250-547



Peripheral Devices and Options (continued)

DC Reactor (UZDA-B for DC circuit)

Base device selection on motor capacity.

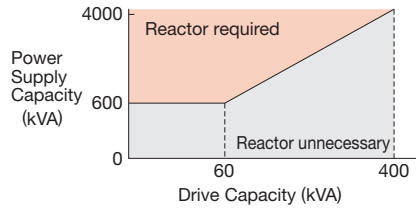
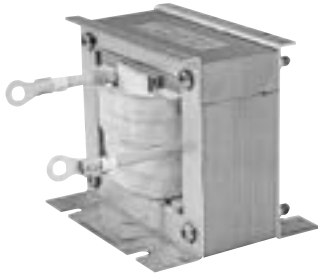

Note: Reactor recommended for power supplies larger than 600 kVA. Use an AC reactor if power supply is 0.2 kW or smaller.

Connection Diagram

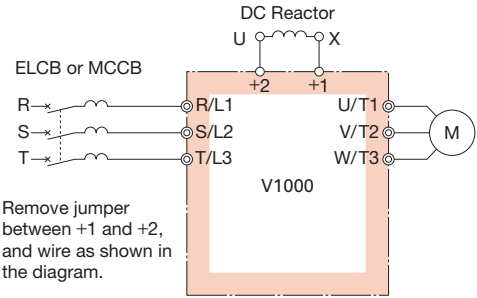

Dimensions (mm)

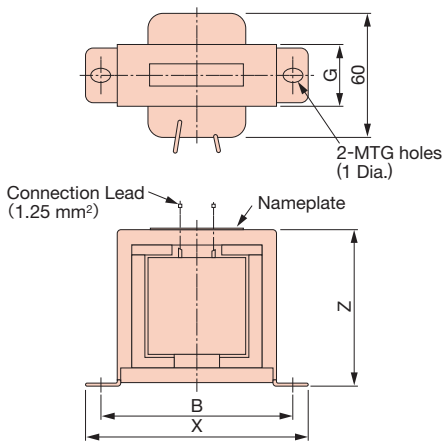

Figure 1

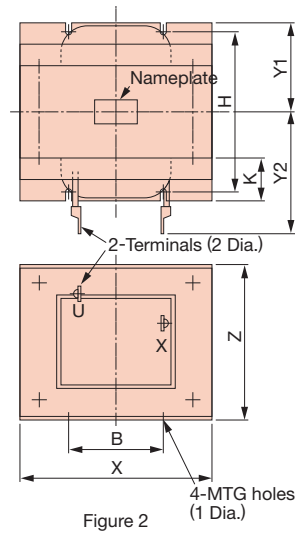

Figure 2

Three-Phase 200 V Class

Motor Capacity (kW)	Current (A)	Inductance (mH)	Code No.	Figure	Dimensions (mm)										Weight (kg)	Watt Loss (W)	Wire Gauge* (mm²)
					X	Y2	Y1	Z	B	H	K	G	1 Dia.	2 Dia.			
0.4 0.75	5.4	8	100-250-672	1	85	-	-	53	74	-	-	32	M4	-	0.8	8	2
1.5 2.2	18	3	100-250-660	2	86	80	36	76	60	55	18	-	M4	M5	2	18	5.5
3.7 5.5	36	1	100-250-668		105	90	46	93	64	80	26	-	M6	M6	3.2	22	8
7.5 11	72	0.5	100-250-677		105	105	56	93	64	100	26	-	M6	M8	4.9	29	30
15 18.5			100-250-679		133	120	52.5	117	86	80	25	-	M6	M8	6.5	45	30

Note: 1. Refer to the technical documentation for the 200 V class, single-phase input series. Contact Yaskawa or your nearest sales representative for more details.
2. Use an AC reactor for a motor capacity of 0.2 kW or less.

Three-Phase 400 V Class

Motor Capacity (kW)	Current (A)	Inductance (mH)	Code No.	Figure	Dimensions (mm)										Weight (kg)	Watt Loss (W)	Wire Gauge* (mm²)
					X	Y2	Y1	Z	B	H	K	G	1 Dia.	2 Dia.			
0.4 0.75	3.2	28	100-250-664	1	85	-	-	53	74	-	-	32	M4	-	0.8	9	2
1.5 2.2	5.7	11	100-250-674		90	-	-	60	80	-	-	32	M4	-	1	11	2
3.7 5.5	12	6.3	100-250-658	2	86	80	36	76	60	55	18	-	M4	M5	2	16	2
7.5 11	23	3.6	100-250-662		105	90	46	93	64	80	26	-	M6	M5	3.2	27	5.5
15 18.5	33	1.9	100-250-666		105	95	51	93	64	90	26	-	M6	M6	4	26	8
	47	1.3	100-250-670		115	125	57.5	100	72	90	25	-	M6	M6	6	42	14
			100-250-670		115	125	57.5	100	72	90	25	-	M6	M6	6	42	14

*: Cable: IV, 75°C, ambient temperature 45°C, 3 lines max.

Terminal Type



Dimensions (mm)

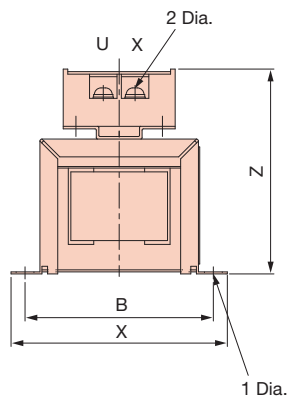

Figure 1

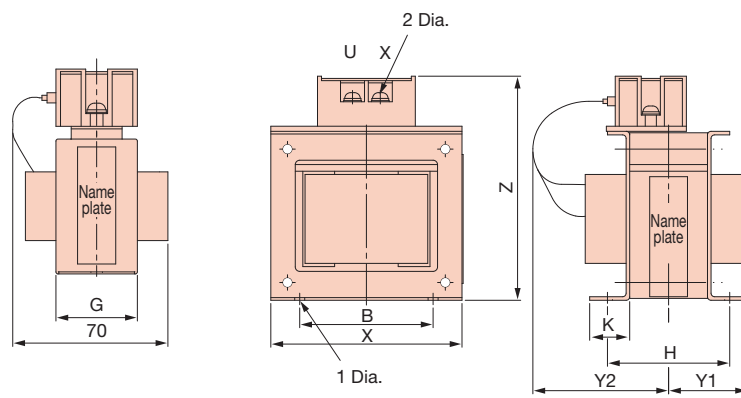

Figure 2

200 V Class

Motor Capacity (kW)	Current (A)	Inductance (mH)	Code No.	Figure	Dimensions (mm)										Weight (kg)	Watt Loss (W)
					X	Y2	Y1	Z	B	H	K	G	1 Dia.	2 Dia.		
0.4	5.4	8	100-250-673	1	85	-	-	81	74	-	-	32	M4	M4	0.8	8
0.75																
1.5																
2.2	18	3	100-250-661	2	86	84	36	101	60	55	18	-	M4	M4	2	18
3.7																
5.5	36	1	100-250-669	2	105	94	46	129	64	80	26	-	M6	M4	3.2	22
7.5																
11	72	0.5	100-250-678	2	105	124	56	135	64	100	26	-	M6	M6	4.9	29
15																
18.5	90	0.4	100-250-680	2	133	147.5	52.5	160	86	80	25	-	M6	M6	6.5	44

400 V Class

Motor Capacity (kW)	Current (A)	Inductance (mH)	Code No.	Figure	Dimensions (mm)										Weight (kg)	Watt Loss (W)
					X	Y2	Y1	Z	B	H	K	G	1 Dia.	2 Dia.		
0.4	3.2	28	100-250-665	1	85	-	-	81	74	-	-	32	M4	M4	0.8	9
0.75																
1.5	5.7	11	100-250-675	1	90	-	-	88	80	-	-	32	M4	M4	1	11
2.2																
3.7	12	6.3	100-250-659	2	86	84	36	101	60	55	18	-	M4	M4	2	16
5.5																
7.5	23	3.6	100-250-663	2	105	104	46	118	64	80	26	-	M6	M4	3.2	27
11																
15	33	1.9	100-250-667	2	105	109	51	129	64	90	26	-	M6	M4	4	26
18.5																
18.5	47	1.3	100-250-671	2	115	142.5	57.5	136	72	90	25	-	M6	M5	6	42



AC Reactor (UZBA-B for Input 50/60 Hz)

Base device selection on motor capacity.

Connection Diagram

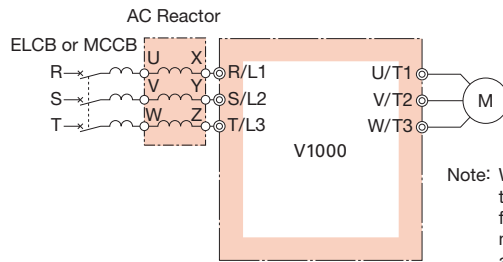

Note: When using low noise type drives (high-carrier frequency of 2.5 kHz or more), do not connect an AC reactor to the output side (U, V, W) of the drive.

Dimensions (mm)

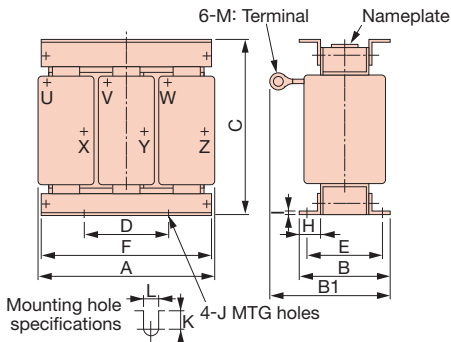

Figure 1

Three-Phase 200 V Class

Motor Capacity (kW)	Current (A)	Inductance (mH)	Code No.	Figure	Dimensions (mm)											Weight (kg)	Watt Loss (W)		
					A	B	B1	C	D	E	F	H	I	J	K			L	M
3.7	20	0.53	100-250-562	1	130	88	114	105	50	70	130	22	3.2	M6	11.5	7	M5	3	35
5.5	30	0.35	100-250-578			98	139			80					9				45
7.5	40	0.265	100-250-584			98	139			80					11.5				50
11	60	0.18	100-250-594		160	105	147.5	130	75	85	160	25	2.3	M6	10	7	M6	6	65
15	80	0.13	100-250-599		180	100	155	150	75	80	180	25			M6	10	7	M8	8
18.5	90	0.12	100-250-602				150						90	90					

Note: Refer to the technical documentation for the 200 V class, single-phase input series. Contact Yaskawa or your nearest sales representative for more details.

Three-Phase 400 V Class

Motor Capacity (kW)	Current (A)	Inductance (mH)	Code No.	Figure	Dimensions (mm)											Weight (kg)	Watt Loss (W)		
					A	B	B1	C	D	E	F	H	I	J	K			L	M
7.5	20	1.06	100-250-564	1	160	90	115	130	75	70	160	25	2.3	M6	10	7	M5	5	50
11	30	0.7	100-250-580			105	132.5			85								6	65
15	40	0.53	100-250-586		180	100	140	150	75	80	180	25		M6	10	7	M6	8	90
18.5	50	0.42	100-250-590				145												90

Terminal Type

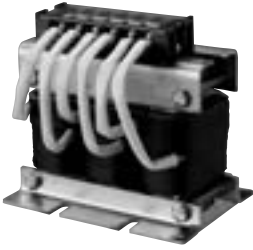

Dimensions (mm)

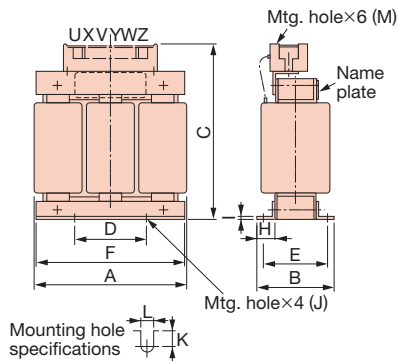

Figure 1

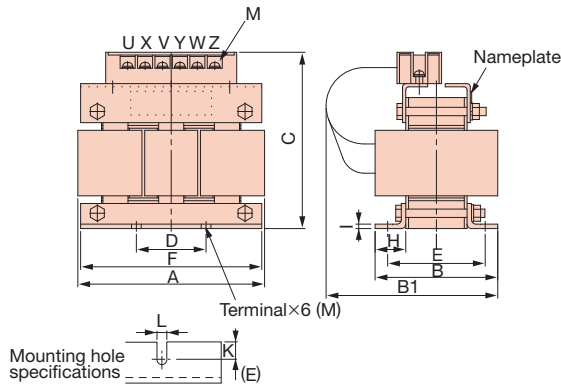

Figure 2

200 V Class

Motor Capacity (kW)	Current (A)	Inductance (mH)	Code No.	Figure	Dimensions (mm)												Weight (kg)	Watt Loss (W)								
					A	B	B1	C	D	E	F	H	I	J	K	L			M							
0.1	2	7	100-250-577	1	120	71	-	115	40	50	105	20	2.3	M6	10.5	7	M4	2.5	15							
0.2	2	7						120																		
0.4	2.5	4.2						100-250-558																		
0.75	5	2.1						100-250-592																		
1.5	10	1.1						100-250-550																		
2.2	15	0.71	100-250-555	130	88	130	50	70	130	22	3.2	9	3	25	30											
3.7	20	0.53	100-250-563	2	135	88	140	130	50	70	130	22	3.2	M6	9	7	M4	3	35							
5.5	30	0.35	100-250-579				150										80	M5	4	50						
7.5	40	0.265	100-250-585				98										160	140	85	160	6	65				
11	60	0.18	100-250-595				105										185	170	75	80	180	25	2.3	M6	8	75
15	80	0.13	100-250-600				185										100	180	195	80	180	25	2.3	M6	8	90

400 V Class

Motor Capacity (kW)	Current (A)	Inductance (mH)	Code No.	Figure	Dimensions (mm)												Weight (kg)	Watt Loss (W)											
					A	B	B1	C	D	E	F	H	I	J	K	L			M										
0.2	1.3	18	100-250-549	1	120	71	-	120	40	50	105	20	2.3	M6	10.5	7	M4	2.5	15										
0.4	1.3	18						120																					
0.75	2.5	8.4						100-250-559																					
1.5	5	4.2						100-250-593																					
2.2	7.5	3.6						100-250-598																					
3.7	10	2.2	100-250-551	130	88	130	50	70	130	22	3.2	9	3	25	40														
5.5	15	1.42	100-250-556	2	165	90	160	155	75	70	160	25	2.3	M6	10	7	M4	5	50										
7.5	20	1.06	100-250-565				175										85	6	65										
11	30	0.7	100-250-581				105										175	155	85	160	25	2.3	M6	10	7	M4	6	65	
15	40	0.53	100-250-587				185										100	170	185	80	180	25	2.3	M6	10	7	M5	8	90
18.5	50	0.42	100-250-591				185										100	170	185	80	180	25	2.3	M6	10	7	M5	8	90



Zero Phase Reactor

Zero-phase reactor should match wire gauge.*

*: Current values for wire gauges may vary based on electrical codes.

The table below lists selections based on Japanese electrical standards and Yaskawa's ND rating. Contact Yaskawa for questions regarding UL.

FINEMET Zero-Phase Reactor to Reduce Radio Noise Note: FINEMET is a registered trademark of Hitachi Metals, Ltd.



[Hitachi Metals, Ltd.]

Connection Diagram

Compatible with the input and output side of the drive.

Example: Connection to output terminal

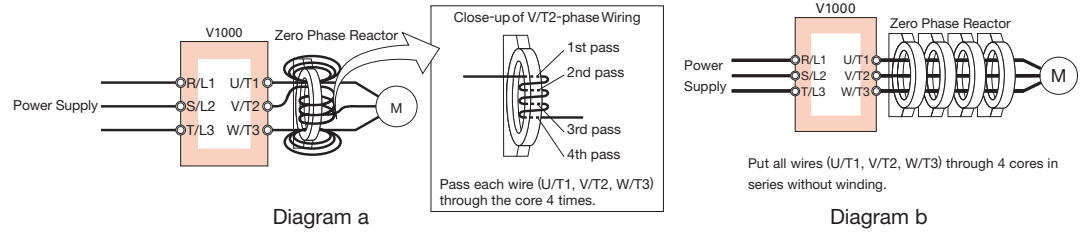

Dimensions (mm)

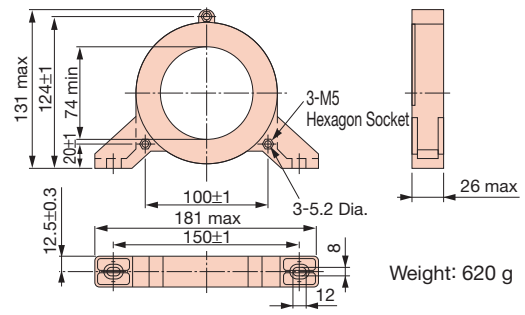
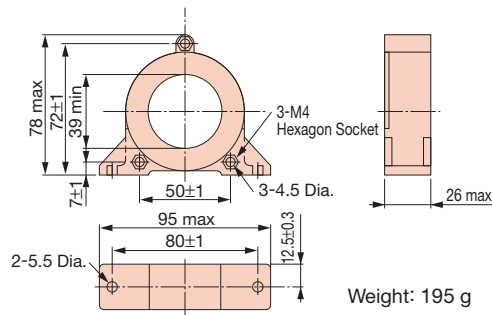

Three-Phase 200 V Class

V1000		Zero Phase Reactor			
Motor Capacity (kW)	Recommended Gauge (mm ²)	Model	Code No.	Qty.	Diagram
0.1	2	F6045GB	100-250-745	1	a
0.2	2	F6045GB	100-250-745	1	a
0.4	2	F6045GB	100-250-745	1	a
0.75	2	F6045GB	100-250-745	1	a
1.5	2	F6045GB	100-250-745	1	a
2.2	2	F6045GB	100-250-745	1	a
3.7	3.5	F6045GB	100-250-745	1	a
5.5	5.5	F6045GB	100-250-745	1	a
7.5	8	F11080GB	100-250-743	1	a
11	14	F6045GB	100-250-745	4	b
15	22	F6045GB	100-250-745	4	b
18.5	30	F6045GB	100-250-745	4	b

Three-Phase 400 V Class

V1000		Zero Phase Reactor			
Motor Capacity (kW)	Recommended Gauge (mm ²)	Model	Code No.	Qty.	Diagram
0.2	2	F6045GB	100-250-745	1	a
0.4	2	F6045GB	100-250-745	1	a
0.75	2	F6045GB	100-250-745	1	a
1.5	2	F6045GB	100-250-745	1	a
2.2	2	F6045GB	100-250-745	1	a
3.0	2	F6045GB	100-250-745	1	a
3.7	2	F6045GB	100-250-745	1	a
5.5	2	F6045GB	100-250-745	1	a
7.5	5.5	F6045GB	100-250-745	1	a
11	5.5	F6045GB	100-250-745	1	a
15	14	F6045GB	100-250-745	4	b
18.5	14	F6045GB	100-250-745	4	b

Single-Phase 200 V Class

V1000		Zero Phase Reactor			
Motor Capacity (kW)	Recommended Gauge (mm ²)	Model	Code No.	Qty.	Diagram
0.1	2	F6045GB	100-250-745	1	a
0.2	2	F6045GB	100-250-745	1	a
0.4	2	F6045GB	100-250-745	1	a
0.75	2	F6045GB	100-250-745	1	a
1.5	2	F6045GB	100-250-745	1	a
2.2	3.5	F6045GB	100-250-745	1	a
3.7	8	F11080GB	100-250-743	1	a

Fuse/Fuse Holder

Install a fuse to the drive input terminals to prevent damage in case a fault occurs.

Refer to the instruction manual for information on UL-approved components.

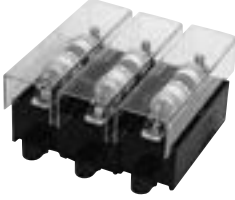

[Fuji Electric]

Three-Phase 200 V Class

Model CIMR-VA2A	AC Power Supply / DC Power Supply							
	Fuse				Fuse Holder			
Model	Code No.	Rated Short-Circuit Breaking Current (kA)	Qty.*	Model	Code No.	Qty.*	Figure	
0001	CR6L-20/UL	100-250-758	100	3				
0002	CR6L-20/UL	100-250-758		3				
0004	CR6L-20/UL	100-250-758		3				
0006	CR6L-30/UL	100-250-777		3	CMS-4	FU002091	3	1
0008	CR6L-50/UL	100-250-781		3				
0010	CR6L-50/UL	100-250-781		3				
0012	CR6L-50/UL	100-250-781		3				
0018	CR6L-75/UL	100-250-761		3				
0020	CR6L-75/UL	100-250-761		3				
0030	CR6L-100/UL	100-250-756		3	CMS-5	FU002092	3	2
0040	CR6L-150/UL	100-250-757		3				
0056	CR6L-150/UL	100-250-757		3				
0069	CR6L-200/UL	100-250-759		3	Note			

* : Multiple fuses are needed when using an AC power supply. DC power requires only two fuses.
Note: Manufacturer does not recommend a specific fuse holder for this fuse.
Contact the manufacturer for information on fuse dimensions.

Single-Phase 200 V Class

Model CIMR-VABA	AC Power Supply / DC Power Supply							
	Fuse				Fuse Holder			
Model	Code No.	Rated Short-Circuit Breaking Current (kA)	Qty.	Model	Code No.	Qty.	Figure	
0001	CR6L-20/UL	100-250-758	100	2				
0002	CR6L-30/UL	100-250-777		2	CMS-4	FU002091	2	1
0003	CR6L-50/UL	100-250-781		2				
0006	CR6L-75/UL	100-250-761		2				
0010	CR6L-100/UL	100-250-756		2	CMS-5	FU002092	2	1
0012	CR6L-100/UL	100-250-756		2				
0018	CR6L-150/UL	100-250-757		2				

Connection Diagram

DC Input Power Supply (example shows two V1000 drives connected in parallel.)
For use with an AC power supply see the connection diagram on page 22.

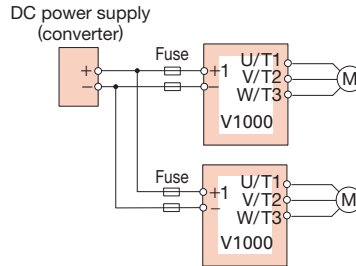

Note: When connecting multiple drives together, make sure that each drive has its own fuse. If any one fuse blows, all fuses should be replaced.

Three-Phase 400 V Class

Model CIMR-VA4A	AC Power Supply / DC Power Supply							
	Fuse				Fuse Holder			
Model	Code No.	Rated Short-Circuit Breaking Current (kA)	Qty.*	Model	Code No.	Qty.*	Figure	
0001	CR6L-20/UL	100-250-758	100	3				
0002	CR6L-20/UL	100-250-758		3				
0004	CR6L-50/UL	100-250-781		3				
0005	CR6L-50/UL	100-250-781		3	CMS-4	FU002091	3	1
0007	CR6L-50/UL	100-250-781		3				
0009	CR6L-50/UL	100-250-781		3				
0011	CR6L-50/UL	100-250-781		3				
0018	CR6L-50/UL	100-250-781		3				
0023	CR6L-75/UL	100-250-761		3				
0031	CR6L-100/UL	100-250-756		3	CMS-5	FU002092	3	2
0038	CR6L-150/UL	100-250-757		3				

* : Multiple fuses are needed when using an AC power supply. DC power requires only two fuses.

Dimensions (mm)

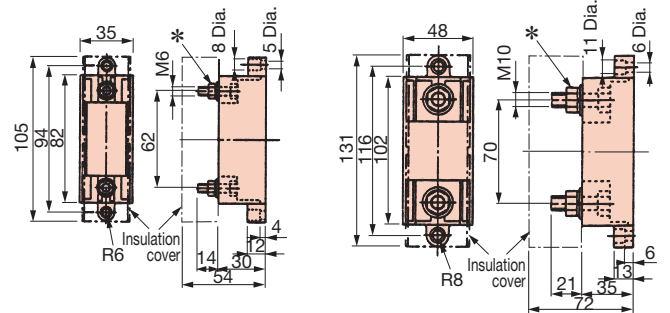

Figure 1

Figure 2

* : Mounting components supplied separately. Tighten bolt when fuse is installed.

Capacitor-type Noise Filter

Capacitor-type noise filter exclusively designed for drive input. The noise filter can be used in combination with a zero-phase reactor. For both 200 V and 400 V classes.

Note: The capacitor-type noise filter can be used for drive input only. Do not connect the noise filter to the output terminals.



[Okaya Electric Industries]

Connection Diagram

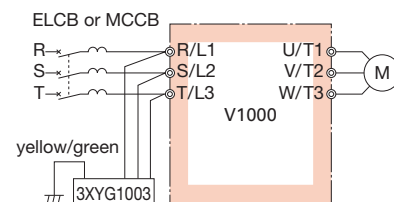

Specifications

Rated Voltage	Capacitance (3 devices each)	Operating Temperature Range (°C)
440 V	X (Δ connection): 0.1 μF ± 20% Y (λ connection): 0.003 μF ± 20%	-40 to +85

Note: For use with 460 V and 480 V units, contact Yaskawa directly.

Dimensions (mm)

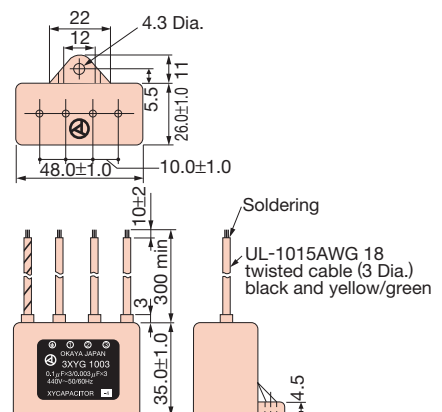



Peripheral Devices and Options (continued)

Input Noise Filter

Base device selection on motor capacity.

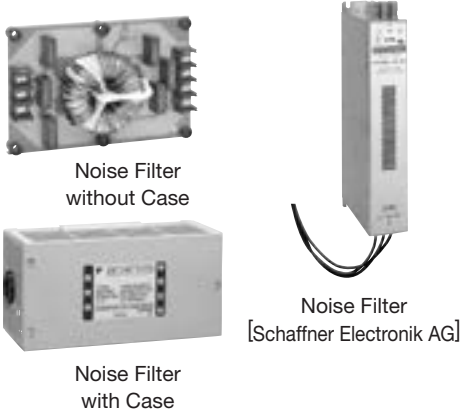

Note: Contact Yaskawa for CE compliant models (EMC directive).

Connection Diagram

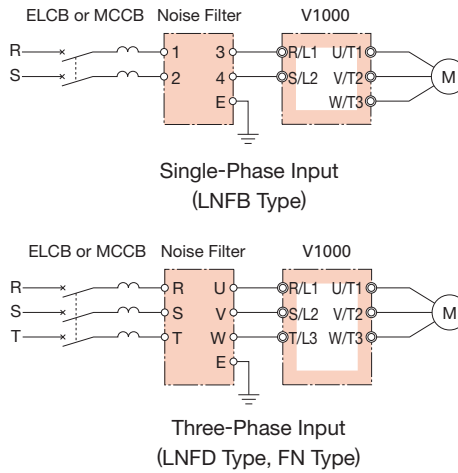

Connecting Noise Filters in Parallel to the Input or Output Side (examples shows two filters in parallel)

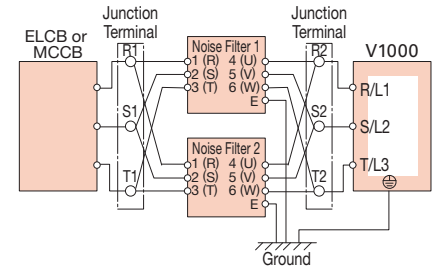

Note: When wiring contactors in parallel, make sure wiring lengths are the same to keep current flow even to the relay terminals. Noise filters and grounding wire should be as heavy and as short as possible.

Note: Do not connect the input noise filter to the drive output terminals (U, V, W). Connect in parallel when using two filters. Only a single noise filter is required if the filter is made by Schaffner Elektronik AG.

Three-Phase 200 V Class

Motor Capacity (kW)	Noise Filter without Case				Noise Filter with Case				Noise Filter by Schaffner Elektronik AG			
	Model	Code No.	Qty.	Rated Current (A)	Model	Code No.	Qty.	Rated Current (A)	Model	Code No.	Qty.	Rated Current (A)
0.1	LNFD-2103DY	100-250-524	1	10	LNFD-2103HY	100-250-525	1	10	—	—	—	—
0.2	LNFD-2103DY	100-250-524	1	10	LNFD-2103HY	100-250-525	1	10	—	—	—	—
0.4	LNFD-2103DY	100-250-524	1	10	LNFD-2103HY	100-250-525	1	10	—	—	—	—
0.75	LNFD-2103DY	100-250-524	1	10	LNFD-2103HY	100-250-525	1	10	—	—	—	—
1.5	LNFD-2103DY	100-250-524	1	10	LNFD-2103HY	100-250-525	1	10	—	—	—	—
2.2	LNFD-2153DY	100-250-526	1	15	LNFD-2153HY	100-250-527	1	15	—	—	—	—
3.7	LNFD-2303DY	100-250-530	1	30	LNFD-2303HY	100-250-531	1	30	—	—	—	—
5.5	LNFD-2203DY	100-250-528	2	40	LNFD-2203HY	100-250-529	2	40	FN258L-42-07	100-250-467	1	42
7.5	LNFD-2303DY	100-250-530	2	60	LNFD-2303HY	100-250-531	2	60	FN258L-55-07	100-250-468	1	55
11	LNFD-2303DY	100-250-530	3	90	LNFD-2303HY	100-250-531	3	90	FN258L-75-34	100-250-470	1	75
15	LNFD-2303DY	100-250-530	3	90	LNFD-2303HY	100-250-531	3	90	FN258L-100-35	100-250-462	1	100
18.5	LNFD-2303DY	100-250-530	4	120	LNFD-2303HY	100-250-531	4	120	FN258L-100-35	100-250-462	1	100

Single-Phase 200 V Class

Motor Capacity (kW)	Noise Filter without Case				Noise Filter with Case			
	Model	Code No.	Qty.	Rated Current (A)	Model	Code No.	Qty.	Rated Current (A)
0.1	LNFB-2102DY	100-250-516	1	10	LNFB-2102HY	100-250-517	1	10
0.2	LNFB-2102DY	100-250-516	1	10	LNFB-2102HY	100-250-517	1	10
0.4	LNFB-2152DY	100-250-518	1	15	LNFB-2152HY	100-250-519	1	15
0.75	LNFB-2202DY	100-250-520	1	20	LNFB-2202HY	100-250-521	1	20
1.5	LNFB-2302DY	100-250-522	1	30	LNFB-2302HY	100-250-523	1	30
2.2	LNFB-2202DY	100-250-520	2	40	LNFB-2202HY	100-250-521	2	40
3.7	LNFB-2302DY	100-250-522	2	60	LNFB-2302HY	100-250-523	2	60

Three-Phase 400 V Class

Motor Capacity (kW)	Noise Filter without Case				Noise Filter with Case				Noise Filter by Schaffner Elektronik AG			
	Model	Code No.	Qty.	Rated Current (A)	Model	Code No.	Qty.	Rated Current (A)	Model	Code No.	Qty.	Rated Current (A)
0.2	LNFD-4053DY	100-250-532	1	5	LNFD-4053HY	100-250-533	1	5	—	—	—	—
0.4	LNFD-4053DY	100-250-532	1	5	LNFD-4053HY	100-250-533	1	5	—	—	—	—
0.75	LNFD-4053DY	100-250-532	1	5	LNFD-4053HY	100-250-533	1	5	—	—	—	—
1.5	LNFD-4103DY	100-250-534	1	10	LNFD-4103HY	100-250-535	1	10	—	—	—	—
2.2	LNFD-4103DY	100-250-534	1	10	LNFD-4103HY	100-250-535	1	10	—	—	—	—
3.7	LNFD-4153DY	100-250-536	1	15	LNFD-4153HY	100-250-537	1	15	—	—	—	—
5.5	LNFD-4203DY	100-250-538	1	20	LNFD-4203HY	100-250-539	1	20	—	—	—	—
7.5	LNFD-4303DY	100-250-540	1	30	LNFD-4303HY	100-250-541	1	30	—	—	—	—
11	LNFD-4203DY	100-250-538	2	40	LNFD-4203HY	100-250-539	2	40	FN258L-42-07	100-250-467	1	42
15	LNFD-4303DY	100-250-540	2	60	LNFD-4303HY	100-250-541	2	60	FN258L-55-07	100-250-468	1	55
18.5	LNFD-4303DY	100-250-540	2	60	LNFD-4303HY	100-250-541	2	60	FN258L-55-07	100-250-468	1	55

Dimensions (mm)
Without Case

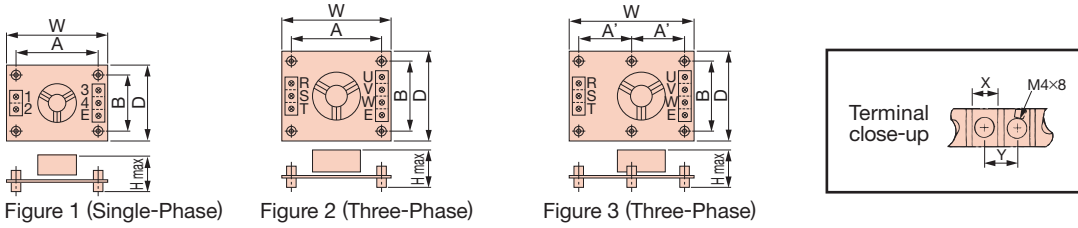
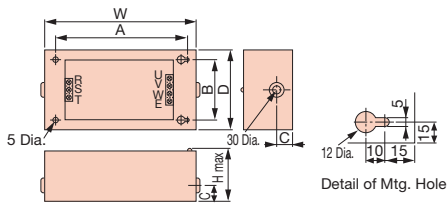

Figure 1 (Single-Phase) Figure 2 (Three-Phase) Figure 3 (Three-Phase)

Model	Code No.	Figure	Dimensions (mm)							Terminal		Mounting Screw	Weight (kg)
			W	D	H	A	A'	B	X	Y			
LNFD-2103DY	100-250-524	2	120	80	55	108	-	68			M4×4,20mm	0.2	
LNFD-2153DY	100-250-526	2	120	80	55	108	-	68	9	11	M4×4,20mm	0.2	
LNFD-2203DY	100-250-528	2	170	90	70	158	-	78			M4×4,20mm	0.4	
LNFD-2303DY	100-250-530	3	170	110	70	-	79	98	10	13	M4×6,20mm	0.5	
LNFB-2102DY	100-250-516	1	120	80	50	108	-	68			M4×4,20mm	0.1	
LNFB-2152DY	100-250-518	1	120	80	50	108	-	68	9	11	M4×4,20mm	0.2	
LNFB-2202DY	100-250-520	1	120	80	50	108	-	68			M4×4,20mm	0.2	
LNFB-2302DY	100-250-522	1	130	90	65	118	-	78	10	13	M4×4,20mm	0.3	
LNFD-4053DY	100-250-532	3	170	130	75	-	79	118			M4×6,30mm	0.3	
LNFD-4103DY	100-250-534	3	170	130	95	-	79	118	9	11	M4×6,30mm	0.4	
LNFD-4153DY	100-250-536	3	170	130	95	-	79	118			M4×6,30mm	0.4	
LNFD-4203DY	100-250-538	3	200	145	100	-	94	133			M4×4,30mm	0.5	
LNFD-4303DY	100-250-540	3	200	145	100	-	94	133	10	13	M4×4,30mm	0.6	

With Case



Note: The figure shows an example of three-phase input.

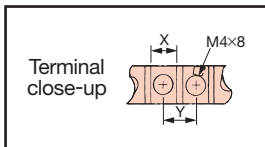

Model	Code No.	Dimensions (mm)						Terminal		Mounting Screw	Weight (kg)
		W	D	H	A	B	C	X	Y		
LNFD-2103HY	100-250-525	185	95	85	155	65	33	9	11	M4×4,10mm	0.9
LNFD-2153HY	100-250-527	185	95	85	155	65	33			M4×4,10mm	0.9
LNFD-2203HY	100-250-529	240	125	100	210	95	33			M4×4,10mm	1.5
LNFD-2303HY	100-250-531	240	125	100	210	95	33	10	13	M4×4,10mm	1.6
LNFB-2102HY	100-250-517	185	95	85	155	65	33			M4×4,10mm	0.8
LNFB-2152HY	100-250-519	185	95	85	155	65	33	9	11	M4×4,10mm	0.8
LNFB-2202HY	100-250-521	185	95	85	155	65	33			M4×4,10mm	0.9
LNFB-2302HY	100-250-523	200	105	95	170	75	33	10	13	M4×4,10mm	1.1
LNFD-4053HY	100-250-533	235	140	120	205	110	43			M4×4,10mm	1.6
LNFD-4103HY	100-250-535	235	140	120	205	110	43	9	11	M4×4,10mm	1.7
LNFD-4153HY	100-250-537	235	140	120	205	110	43			M4×4,10mm	1.7
LNFD-4203HY	100-250-539	270	155	125	240	125	43			M4×4,10mm	2.2
LNFD-4303HY	100-250-541	270	155	125	240	125	43	10	13	M4×4,10mm	2.2

Manufactured by Schaffner Elektronik AG

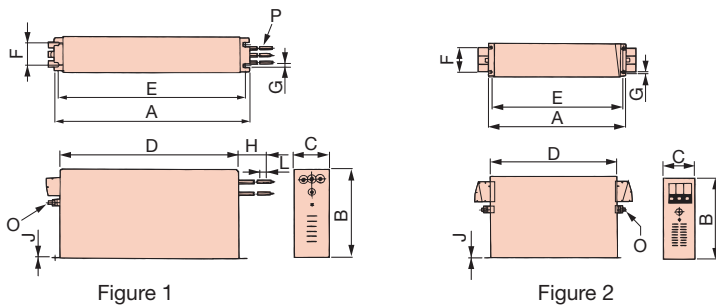

Figure 1

Figure 2

Model	Figure	Dimensions (mm)											Wire Gauge	Weight (kg)
		A	B	C	D	E	F	G	H	J	L	O		
FN258L-42-07	1	329	185±1	70	300	314	45	6.5	500	1.5	12	M6	AWG8	2.8
FN258L-55-07	1	329	185±1	80	300	314	55	6.5	500	1.5	12	M6	AWG6	3.1
FN258L-75-34	2	329	220	80	300	314	55	6.5	-	1.5	-	M6	-	4.0
FN258L-100-35	2	379±1.5	220	90±0.8	350±1.2	364	65	6.5	-	1.5	-	M10	-	5.5

Note: For CE Marking (EMC Directive) compliant models, contact us for inquiry.



Output Noise Filter

Base device selection on motor capacity.



[NEC TOKIN Corporation]

Connection Diagram

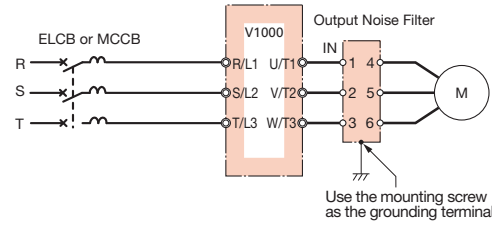

Dimensions (mm)

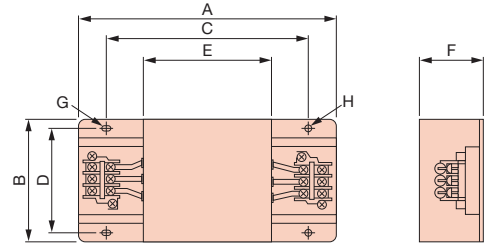

Three/Single-Phase 200 V Class

Motor Capacity (kW)	Model	Code No.	Qty.	Rated Current (A)	Dimensions (mm)								Terminal	Weight (kg)
					A	B	C	D	E	F	G	H		
0.1	LF-310KA	100-250-702	1	10	140	100	100	90	70	45	7×φ4.5	φ4.5	TE-K5.5M4	0.5
0.2	LF-310KA	100-250-702	1	10	140	100	100	90	70	45	7×φ4.5	φ4.5	TE-K5.5M4	0.5
0.4	LF-310KA	100-250-702	1	10	140	100	100	90	70	45	7×φ4.5	φ4.5	TE-K5.5M4	0.5
0.75	LF-310KA	100-250-702	1	10	140	100	100	90	70	45	7×φ4.5	φ4.5	TE-K5.5M4	0.5
1.5	LF-310KA	100-250-702	1	10	140	100	100	90	70	45	7×φ4.5	φ4.5	TE-K5.5M4	0.5
2.2	LF-320KA	100-250-705	1	20	140	100	100	90	70	45	7×φ4.5	φ4.5	TE-K5.5M4	0.6
3.7	LF-320KA	100-250-705	1	20	140	100	100	90	70	45	7×φ4.5	φ4.5	TE-K5.5M4	0.6
5.5	LF-350KA	100-250-709	1	50	260	180	180	160	120	65	7×φ4.5	φ4.5	TE-K22M6	2
7.5	LF-350KA	100-250-709	1	50	260	180	180	160	120	65	7×φ4.5	φ4.5	TE-K22M6	2
11	LF-350KA	100-250-709	2	100	260	180	180	160	120	65	7×φ4.5	φ4.5	TE-K22M6	2
15	LF-350KA	100-250-709	2	100	260	180	180	160	120	65	7×φ4.5	φ4.5	TE-K22M6	2
18.5	LF-350KA	100-250-709	2	100	260	180	180	160	120	65	7×φ4.5	φ4.5	TE-K22M6	2

Three-Phase 400 V Class

Motor Capacity (kW)	Model	Code No.	Qty.	Rated Current (A)	Dimensions (mm)								Terminal	Weight (kg)
					A	B	C	D	E	F	G	H		
0.2	LF-310KB	100-250-703	1	10	140	100	100	90	70	45	7×φ4.5	φ4.5	TE-K5.5M4	0.5
0.4	LF-310KB	100-250-703	1	10	140	100	100	90	70	45	7×φ4.5	φ4.5	TE-K5.5M4	0.5
0.75	LF-310KB	100-250-703	1	10	140	100	100	90	70	45	7×φ4.5	φ4.5	TE-K5.5M4	0.5
1.5	LF-310KB	100-250-703	1	10	140	100	100	90	70	45	7×φ4.5	φ4.5	TE-K5.5M4	0.5
2.2	LF-310KB	100-250-703	1	10	140	100	100	90	70	45	7×φ4.5	φ4.5	TE-K5.5M4	0.5
3.7	LF-310KB	100-250-703	1	10	140	100	100	90	70	45	7×φ4.5	φ4.5	TE-K5.5M4	0.5
5.5	LF-320KB	100-250-706	1	20	140	100	100	90	70	45	7×φ4.5	φ4.5	TE-K5.5M4	0.6
7.5	LF-320KB	100-250-706	1	20	140	100	100	90	70	45	7×φ4.5	φ4.5	TE-K5.5M4	0.6
11	LF-335KB	100-250-707	1	35	140	100	100	90	70	45	7×φ4.5	φ4.5	TE-K5.5M4	0.8
15	LF-335KB	100-250-707	1	35	140	100	100	90	70	45	7×φ4.5	φ4.5	TE-K5.5M4	0.8
18.5	LF-345KB	100-250-708	1	45	260	180	180	160	120	65	7×φ4.5	φ4.5	TE-K22M6	2

● Isolator (Insulation Type DC Transmission Converter)



Connection Diagram

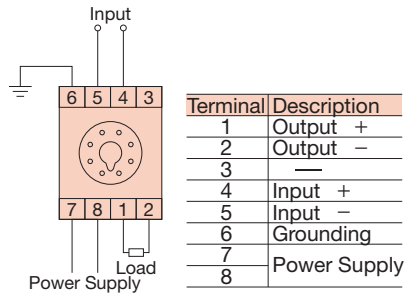

Cable Length

- 4 to 20 mA: within 100 m
- 0 to 10 V: within 50 m

Dimensions (mm)

Model GP Series

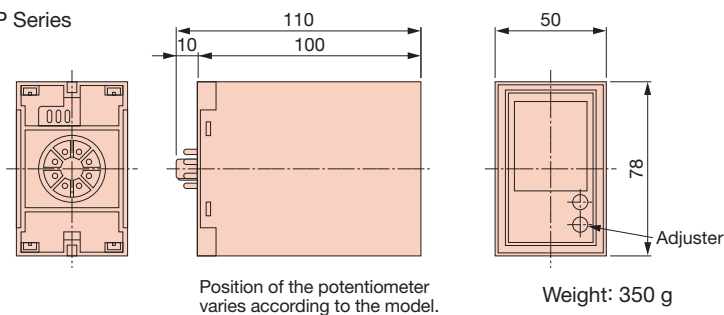

Socket

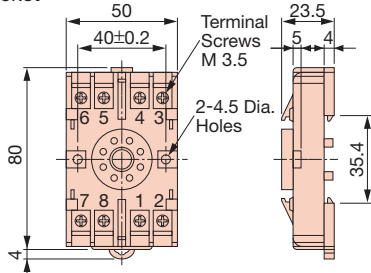

View of Socket Mounting

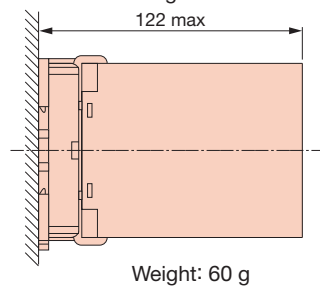

Performance

- | | |
|-----------------------------------|--|
| (1) Allowance | $\pm 0.25\%$ of output span (ambient temp.: 23°C) |
| (2) Temperature Fluctuation | $\pm 0.25\%$ of output span (at $\pm 10^\circ\text{C}$ of ambient temperature) |
| (3) Aux. Power Supply Fluctuation | $\pm 0.1\%$ of output span (at $\pm 10\%$ of aux. power supply) |
| (4) Load Resistance Fluctuation | $\pm 0.05\%$ of output span (in the range of load resistance) |
| (5) Output Ripple | $\pm 0.5\%$ P-P of output span |
| (6) Response Time | 0.5 s or less (time to settle to $\pm 1\%$ of final steady value) |
| (7) Withstand Voltage | 2000 Vac for 60 s (between all terminals and enclosure) |
| (8) Insulation Resistance | 20 M Ω and above (using 500 Vdc megger between each terminal and enclosure) |

Product Line

Model	Input Signal	Output Signal	Power Supply	Code No.
DGP2-4-4	0 to 10 V	0 to 10 V	100 Vac	100-250-732
DGP2-4-8	0 to 10 V	4 to 20 mA	100 Vac	100-250-733
DGP2-8-4	4 to 20 mA	0 to 10 V	100 Vac	100-250-734
DGP2-3-4	0 to 5 V	0 to 10 V	100 Vac	100-250-731
DGP3-4-4	0 to 10 V	0 to 10 V	200 Vac	100-250-736
DGP3-4-8	0 to 10 V	4 to 20 mA	200 Vac	100-250-737
DGP3-8-4	4 to 20 mA	0 to 10 V	200 Vac	100-250-738
DGP3-3-4	0 to 5 V	0 to 10 V	200 Vac	100-250-735



Peripheral Devices and Options (continued)

Braking Resistor, Braking Resistor Unit

Base device selection on motor capacity.

Braking Resistor
[ERF150WJ series]



Braking Resistor
with Fuse
[CF120-B579 series]



Built-in

Braking Resistor
Unit
[LKEB series]



Stand-alone



Stand-alone

Connection Diagram

Set parameter L8-01 to 1 (resistor overheat protection enabled). And, set one of the multi-function digital output terminals (H2-□□) to D (braking resistor fault). With this setting, A sequence in which the power supply will be shut off is required. (When using a braking resistor with fuse, an external sequence is not required)

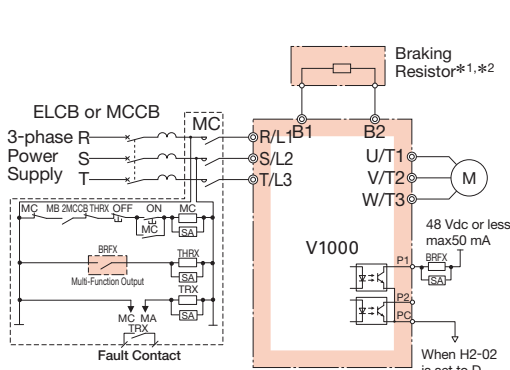

Connection Diagram A

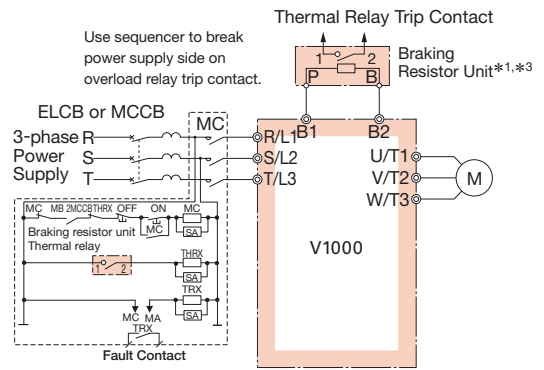

Connection Diagram B

- *1: Disable Stall Prevention during deceleration by setting L3-04 (Stall Prevention Selection during Deceleration) to 0 (Disabled) when using a Braking Resistor or Braking Resistor Unit. The motor may not stop within the deceleration time if this setting is not changed from 1 (Enabled: default).
- *2: Set L8-01 to 1 to enable braking resistor overload protection in the drive when using ERF-type resistors.
- *3: Be sure to protect non-Yaskawa braking resistors by thermal overload relay.

- Note: 1. For connections of the separate type braking unit (CDBR type) without using the built-in braking transistor, connect the B1 terminal of the drive to the + terminal of the braking resistor unit and connect the - terminal of the drive to the - terminal of the braking resistor unit. The B2 terminal is not used in this case.
2. Multiple braking resistors should be connected in parallel.

Dimensions (mm)

Braking Resistor

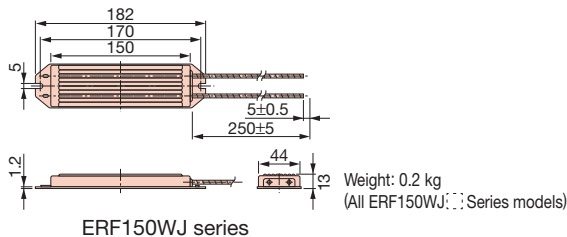

ERF150WJ series

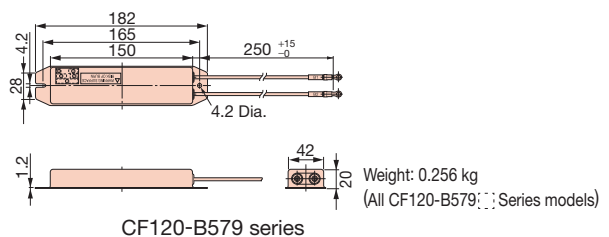

CF120-B579 series

Braking Resistor Unit

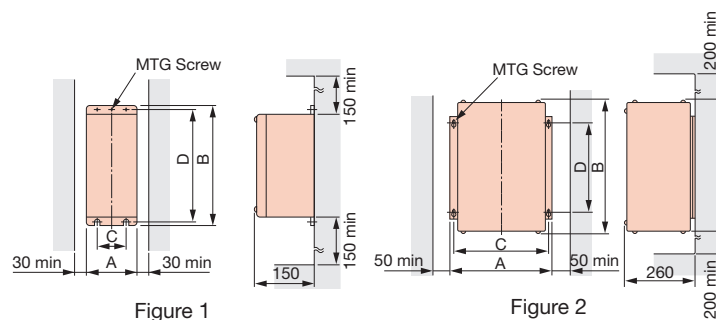

Figure 1

Figure 2

Braking Resistor Unit Model	Figure	Dimensions (mm)				MTG Screw	Weight (kg)	Allowable Average Power Consumption (W)	
		A	B	C	D				
200 V Class	20P7	1	105	275	50	260	M5×3	3	30
	21P5	1	130	350	75	335	M5×4	4.5	60
	22P2	1	130	350	75	335	M5×4	4.5	89
	23P7	1	130	350	75	335	M5×4	5	150
	25P5	1	250	350	200	335	M6×4	7.5	220
	27P5	1	250	350	200	335	M6×4	8.5	300
	2011	2	266	543	246	340	M8×4	10	440
400 V Class	2015	2	356	543	336	340	M8×4	15	600
	40P7	1	105	275	50	260	M5×3	3	30
	41P5	1	130	350	75	335	M5×4	4.5	60
	42P2	1	130	350	75	335	M5×4	4.5	89
	43P7	1	130	350	75	335	M5×4	5	150
	45P5	1	250	350	200	335	M6×4	7.5	220
	47P5	1	250	350	200	335	M6×4	8.5	300
	4011	2	350	412	330	325	M6×4	16	440
4015	2	350	412	330	325	M6×4	18	600	
4018	2	446	543	426	340	M8×4	19	740	

Standard Specifications and Applications

Three/Single-Phase 200 V Class

Max. Motor Capacity (kW)	ND/HD	V1000		Braking Resistor (Duty Factor: 3% ED, 10 s max.)*1										Braking Resistor Unit (Duty Factor: 10% ED, 10 s max.)*1				Min*2 Connectable Resistor (Ω)	
		Three-Phase CIMR-VA2A	Single-Phase CIMR-VABA	No Fuse					With Fuse					Model LKEB-	Resistor Specifications (per unit)	Qty.	Diagram		Braking Torque*3 (%)
				Model ERF150WJ	Resistance (Ω)	Qty.	Diagram	Braking Torque*3 (%)	Model CF120-B579	Resistance (Ω)	Qty.	Diagram	Braking Torque*3 (%)						
0.1	HD	0001	0001	401	400	1	A	220	A	400	1	A	220	40P7	70W 750Ω	1	B	220	300
0.2	ND	0001	0001	401	400	1	A	220	A	400	1	A	220	40P7	70W 750Ω	1	B	125	300
	HD	0002	0002																
0.4	ND	0002	0002	401	400	1	A	110	A	400	1	A	110	40P7	70W 750Ω	1	B	65	300
	HD	0004	0003	201	200			220	B	200			220	20P7	70W 200Ω			220	
0.75	ND	0004	0003	201	200	1	A	125	B	200	1	A	125	20P7	70W 200Ω	1	B	125	200
	HD	0006	0006															120	
1.1	ND	0006	0006	201	200	1	A	85	B	200	1	A	85	20P7	70W 200Ω	1	B	85	120
	HD	0008	—	101	100			150	C	100			150	21P5	260W 100Ω			150	60
1.5	ND	0008	—	101	100	1	A	125	C	100	1	A	125	21P5	260W 100Ω	1	B	125	60
	HD	0010	0010																
2.2	ND	0010	0010	700	70	1	A	120	D	70	1	A	120	22P2	260W 70Ω	1	B	120	60
	HD	0012	0012																
3.0	ND	0012	0012	620	62	1	A	100	E	62	1	A	100	22P2	260W 70Ω	1	B	90	60
	HD	0018	—											23P7	390W 40Ω			150	32
3.7	ND	0018	—	620	62	1	A	80	E	62	1	A	80	23P7	390W 40Ω	1	B	125	32
	HD	0020	0018																
5.5	ND	0020	—	—	—	—	—	—	—	—	—	—	—	23P7	390W 40Ω	1	B	85	32
	HD	0030	—	—	—	—	—	—	—	—	—	—	—					25P5	520W 30Ω
7.5	ND	0030	—	—	—	—	—	—	—	—	—	—	—	27P5	780W 20Ω	1	B	125	9.6
	HD	0040	—	—	—	—	—	—	—	—	—	—	—						
11	ND	0040	—	—	—	—	—	—	—	—	—	—	—	2011	2400W 13.6Ω	1	B	125	9.6
	HD	0056	—	—	—	—	—	—	—	—	—	—	—						
15	ND	0056	—	—	—	—	—	—	—	—	—	—	—	2015	3000W 10Ω	1	B	125	9.6
	HD	0069	—	—	—	—	—	—	—	—	—	—	—						
18.5	ND	0069	—	—	—	—	—	—	—	—	—	—	—	2015	3000W 10Ω	1	B	100	9.6

Three-Phase 400 V Class

Max. Motor Capacity (kW)	ND/HD	V1000		Braking Resistor (Duty Factor: 3% ED, 10 s max.)*1										Braking Resistor Unit (Duty Factor: 10% ED, 10 s max.)*1				Min*2 Connectable Resistor (Ω)	
		Three-Phase CIMR-VA4A		No Fuse					With Fuse					Model LKEB-	Resistor Specifications (per unit)	Qty.	Diagram		Braking Torque*3 (%)
				Model ERF150WJ	Resistance (Ω)	Qty.	Diagram	Braking Torque*3 (%)	Model CF120-B579	Resistance (Ω)	Qty.	Diagram	Braking Torque*3 (%)						
0.2	HD	0001		751	750	1	A	230	F	750	1	A	230	40P7	70W 750Ω	1	B	230	750
0.4	ND	0001		751	750	1	A	230	F	750	1	A	230	40P7	70W 750Ω	1	B	230	750
	HD	0002																	
0.75	ND	0002		751	750	1	A	130	F	750	1	A	130	40P7	70W 750Ω	1	B	130	750
	HD	0004																510	
1.5	ND	0004		751	750	1	A	70	F	750	1	A	70	40P7	70W 750Ω	1	B	70	510
	HD	0005		401	400			125	G	400			125	41P5	260W 400Ω			125	240
2.2	ND	0005		301	300	1	A	115	H	300	1	A	115	42P2	260W 250Ω	1	B	135	240
	HD	0007																200	
3.0	ND	0007		401	400	2	A	125	J	250	1	A	100	42P2	260W 250Ω	1	B	100	200
	HD	0009												43P7	390W 150Ω			150	100
3.7	ND	0009		401	400	2	A	105	J	250	1	A	83	43P7	390W 150Ω	1	B	135	100
	HD	0011																	
5.5	ND	0011		201	200	2	A	135	J	250	2	A	105	45P5	520W 100Ω	1	B	135	100
	HD	0018		—	—													—	—
7.5	ND	0018		—	—	—	—	—	—	—	—	—	—	47P5	780W 75Ω	1	B	130	32
	HD	0023		—	—	—	—	—	—	—	—	—	—						
11	ND	0023		—	—	—	—	—	—	—	—	—	—	4011	1040W 50Ω	1	B	135	32
	HD	0031		—	—	—	—	—	—	—	—	—	—					20	
15	ND	0031		—	—	—	—	—	—	—	—	—	—	4015	1560W 40Ω	1	B	125	20
	HD	0038		—	—	—	—	—	—	—	—	—	—						
18.5	ND	0038		—	—	—	—	—	—	—	—	—	—	4018	4800W 32Ω	1	B	125	20

*1: Refers to a motor coasting to stop with a constant torque load. Constant output and regenerative braking will reduce the duty factor.
 *2: The braking unit should have a resistance higher than the minimum connectable resistance value and be able to generate enough braking torque to stop the motor.
 *3: Applications with a relatively large amount of regenerative power (elevators, hoists, etc.) may require more braking power than is possible with only the standard braking unit and braking resistor. If the braking torque exceeds the value shown in the table, a braking resistor of a higher capacity must be selected.
 Note: If the built-in fuse on a braking resistor blows, then the entire braking resistor should be replaced.



Peripheral Devices and Options (continued)

24 V Power Supply

The 24 V Power Supply Option maintains drive control circuit power in the event of a main power outage. The control circuit keeps the network communications and I/O data operational in the event of a power outage. It supplies external power to the control circuit only.

Note: Parameter settings can be accessed but cannot be changed when the drive is operating solely from this power supply.



The installed option adds 34 mm to the total depth of the drive.

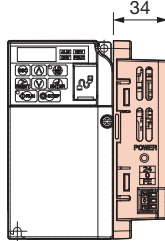

Connection Diagram

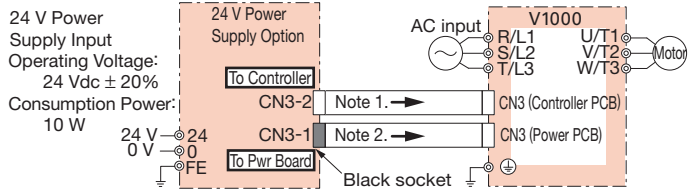

- Note: 1. This cable with "white" connector ends is supplied with the PS-V10M Option.
 2. This cable with "black" connector ends is supplied with the PS-V10S Option.

The mounting support bracket is required for UL Type 1. If these supports are not used, the design is considered "Open Type."

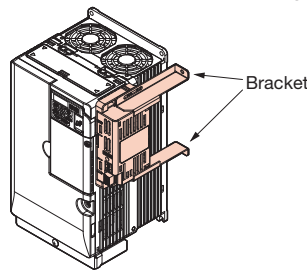

Drive with PS-V10M

Voltage Class	Model CIMR-VA	24 V Power Supply		Bracket	
		Model	Code No.	Model	Code No.
200 V Class (Three-Phase)	2A0001B	PS-V10S	100-038-701	EZZ020639A	100-039-821
	2A0002B				
	2A0004B				
	2A0006B				
	2A0008B				
	2A0010B	PS-V10S	100-038-701	EZZ020639B	100-039-822
	2A0012B				
	2A0018B				
	2A0020B				
	2A0030F	PS-V10M	100-038-702	EZZ020639B	100-039-822
	2A0040F				
2A0056F	PS-V10M	100-038-702	EZZ020639C	100-039-823	
2A0069F					
200 V Class (Single-Phase)	BA0001B	PS-V10S	100-038-701	EZZ020639A	100-039-821
	BA0002B				
	BA0003B				
	BA0006B	PS-V10S	100-038-701	EZZ020639B	100-039-822
	BA0010B				
	BA0012B				
	BA0018B				
400 V Class (Three-Phase)	4A0001B	PS-V10S	100-038-701	EZZ020639A	100-039-821
	4A0002B				
	4A0004B				
	4A0005B				
	4A0007B				
	4A0009B	PS-V10S	100-038-701	EZZ020639B	100-039-822
	4A0011B				
	4A0018F				
	4A0023F	PS-V10M	100-038-702	EZZ020639B	100-039-822
	4A0031F				
4A0038F					
		PS-V10M	100-038-702	EZZ020639C	100-039-823

● USB Copy Unit (Model: JVOP-181)

Copy parameter settings in a single step, then transfer those settings to another drive.
Connects to the RJ-45 port on the drive and to the USB port of a PC.

Connection

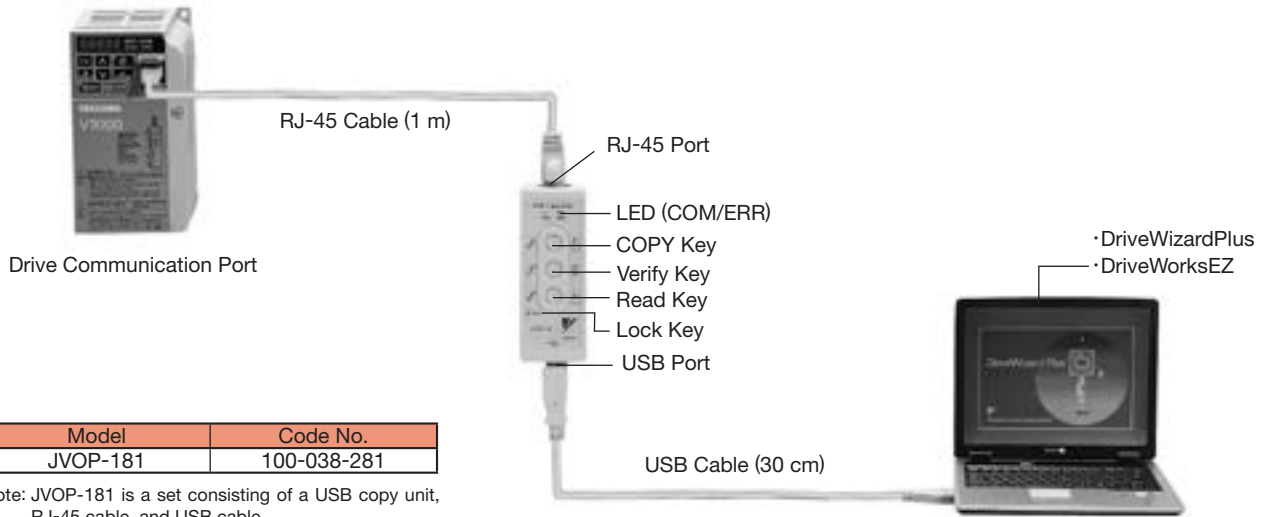

Model	Code No.
JVOP-181	100-038-281

Note: JVOP-181 is a set consisting of a USB copy unit, RJ-45 cable, and USB cable.

Specifications

Item	Specifications	
Port	LAN (RJ-45) : Connect to the drive.	
	USB (Ver.2.0 compatible) : Connect to the PC as required.	
Power Supply	Supplied from a PC or the drive	
Operating System	OS compatible with 32-bit memory	Windows 2000
	OS compatible with 32-bit and 64-bit memory	Windows XP
Memory	Memorizes the parameters for one drive.	
Dimensions	30 (W) × 80 (H) × 20 (D) mm	
Included	RJ-45 cable (1 m), USB cable (30 cm)	

- Note: 1. Drives must have identical software versions to copy parameters settings.
2. Requires a USB driver.
You can download the driver for free from Yaskawa's product and technical information website (<http://www.e-mechatronics.com>).
3. Parameter copy function disabled when connected to a PC.

PC USB Connector

- Note: 1. You can also use a commercially available USB 2.0 cable (with A-B connectors) for the USB cable.
2. No USB cable is needed to copy parameters to other drives.

● PC Cable (Model: WV103)

Cable to connect the drive to a PC with DriveWizard Plus or DriveWorksEZ installed.

Connection

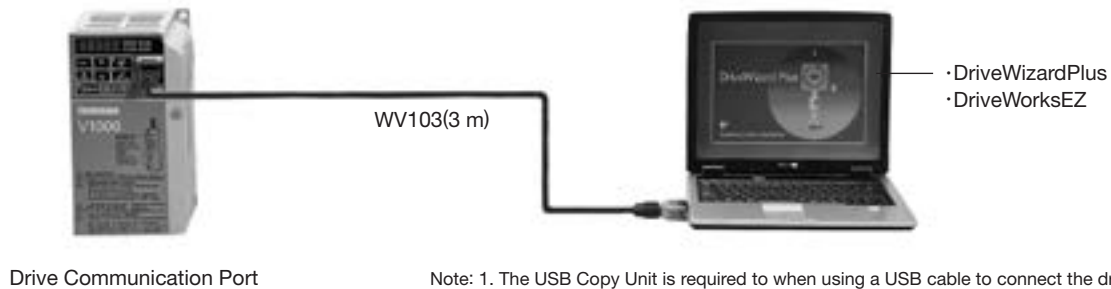

Model	Code No.
WV103	WV103

Specifications

Item	Specifications
Connector	DSUB9P
Cable Length	3 m

- Note: 1. The USB Copy Unit is required to when using a USB cable to connect the drive to a PC.
2. DriveWizard Plus is a PC software package for managing parameters and functions in Yaskawa drives. To order this software, contact your YASKAWA representative.
DriveWorksEZ is the software for creating custom application programs for the drive through visual programming. To order this software, contact our sales representative.



Remote Digital Operator / Operator Extension Cable

Allows for remote operation. Includes a Copy function for saving drive settings.

Connection

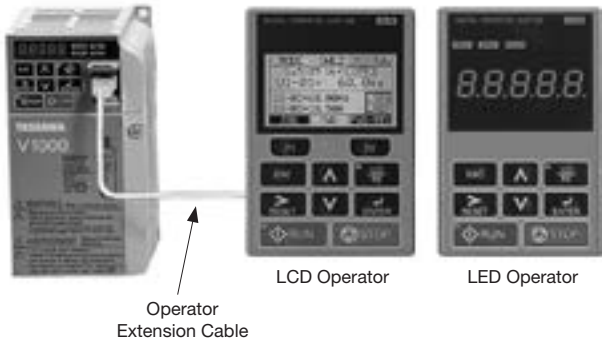

Dimensions (mm)

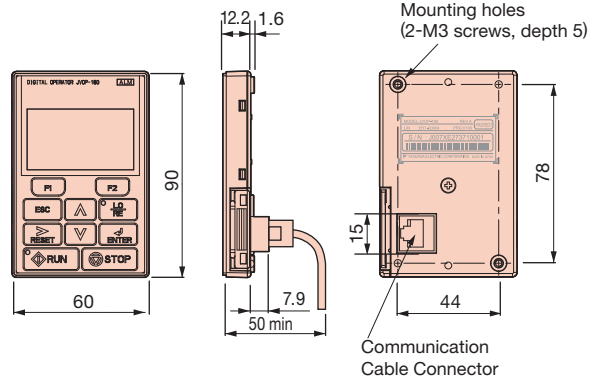

Remote Digital Operator

Item	Model	Code No.
LCD Operator	JVOP-180	100-142-915
LED Operator	JVOP-182	100-142-916

Operator Extension Cable

Model	Code No.	Remarks
WV001 (1 m)	WV001	<ul style="list-style-type: none"> • RJ-45, 8-pin straight-through • UTP CAT5e cable (1 m/3 m) Note: Use straight-through cable. Other cables will cause drive failure.
WV003 (3 m)	WV003	

- Note: 1. Never use this cable for connecting the drive to a PC. Doing so may damage the PC.
 2. You can also use a commercially available LAN cable (straight-through) for the operator extension cable.

This bracket is required to mount the LCD or LED operator outside an enclosure panel.

Item	Code No. (Model)	Installation	Notes
 Installation Support Set A	100-039-992 (EZZ020642A)	 M4×10 truss head screw M3×6 pan head screw 13.9 50 min	For use with holes through the panel
 Installation Support Set B	100-039-993 (EZZ020642B)	 M4 nut M3×6 pan head screw 13.9 50 min	For use with panel mounted threaded studs

Note: If weld studs are on the back of the panel, use the Installation Support Set B.

● Communication Interface Unit



Example of interface installation

Name	Model	Code No.
MECHATROLINK-II Option	SI-T3/V	100-142-929
MECHATROLINK-III Option	SI-ET3/V*	100-106-675
CC-Link Option	SI-C3/V	100-038-064
DeviceNet Option	SI-N3/V	100-142-924
CompoNet Option	SI-M3/V	100-142-923
PROFIBUS-DP Option	SI-P3/V	100-142-926
CANopen Option	SI-S3/V	100-038-739
EtherCAT	SI-ES3/V	100-233-227
EtherNet/IP	SI-EN3/V	100-230-550
Modbus/TCP	SI-EM3/V	100-230-552
PROFINET	SI-EP3/V	100-230-554

*: MECHATROLINK-III SI-ET3/V is available in drive software versions PRG: S1023 and later. Contact Yaskawa for details.

Dimensions (mm)

The interface increases total drive dimensions by 27 mm.

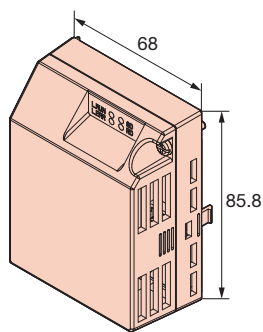

Example: CIMR-VA2A0004

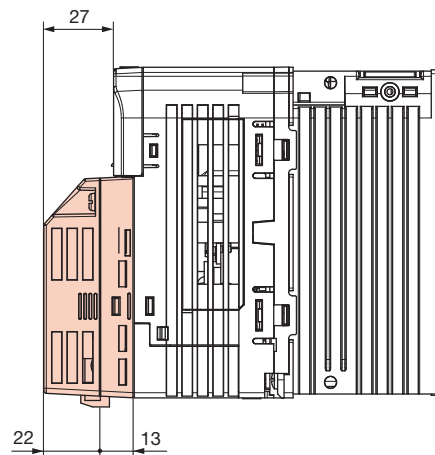



Peripheral Devices and Options (continued)

Momentary Power Loss Recovery Unit (0.1 to 7.5 kW for 200 V/400 V class)



Model	Code No.
200 V Class: P0010	P0010
400 V Class: P0020	P0020

Note: Use this unit for 7.5kW or less to extend the drive's power loss ride-thru ability to 2 s. When this unit is not used, the drive's power loss ride-thru ability is 0.1 to 1 s.

Connection Diagram

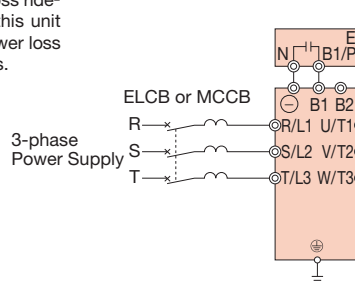

Dimensions (mm)

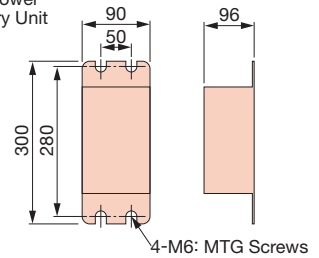

Frequency Meter/Current Meter



Model	Code No.
Scale-75 Hz full-scale: DCF-6A	100-250-730
Scale-65/130 Hz full-scale: DCF-6A	100-250-728
Scale-5 A full-scale: DCF-6A	100-252-699
Scale-10 A full-scale: DCF-6A	100-252-695
Scale-20 A full-scale: DCF-6A	100-252-696
Scale-30 A full-scale: DCF-6A	100-252-697
Scale-50 A full-scale: DCF-6A	100-252-698

Note: DCF-6A is a 3 V, 1 mA frequency meter. The user may want to additionally install a frequency potentiometer to control output (shown below) or set parameter H4-02 to the appropriate output level (0 to 3 V).

Dimensions (mm)

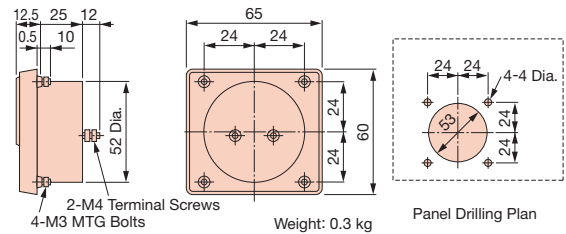

Frequency Setting Potentiometer/Frequency Meter Adjusting Potentiometer



Model	Code No.
RV30YN20S 2 kΩ	100-250-722
RV30YN20S 20 kΩ	100-250-723

Dimensions (mm)

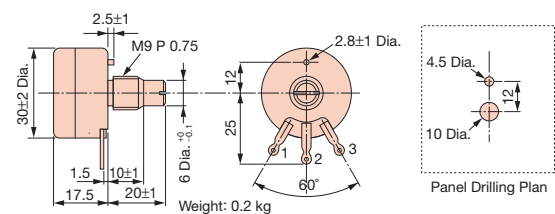

Control Dial for Frequency Setting Potentiometer/Frequency Meter Adjusting Potentiometer

Note: The current product (before change) will be switched out for the replacement product (after change) once stock runs out. Contact a Yaskawa distributor or sales representative for more information.

Before change

After change

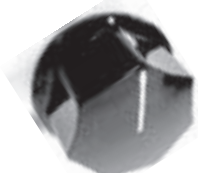

	Before change	After change
Model	CM-3S	K-2901-M
Code No.	100-250-543	300-104-099
Dimensions (mm)	D	32.8
	M	29.9
	H	16.1
Applicable shaft diameter (mm)	6	6
Mounting screw	M4 (2)	M4 (1)

Dimensions (mm)

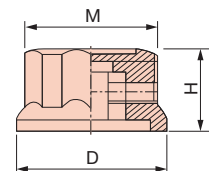

● Meter Plate for Frequency Setting Potentiometer/Frequency Meter Adjusting Potentiometer



Model	Code No.
NPJT41561-1	100-250-701

Dimensions (mm)

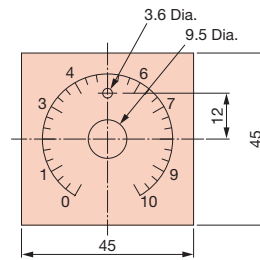

● Output Voltage Meter



Model	Code No.
Scale-300 V full-scale (Rectification Type Class 2.5) : SCF-12NH	VM000481
Scale-600 V full-scale (Rectification Type Class 2.5) : SCF-12NH	VM000502

Dimensions (mm)

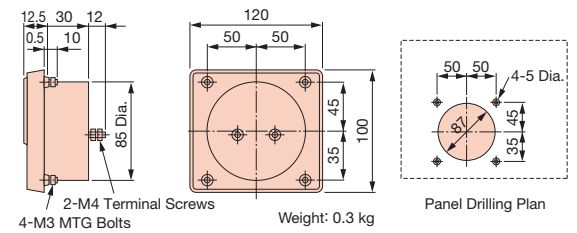

● Potential Transformer



Model	Code No.
600 V meter for voltage transformer UPN-B 440/110 V (400/100 V)	100-011-486

*: For use with a standard voltage regulator.
A standard voltage regulator may not match the drive output voltage. Select a regulator specifically designed for the drive output (100-011-486), or a voltmeter that does not use a transformer and offers direct read out.

Dimensions (mm)

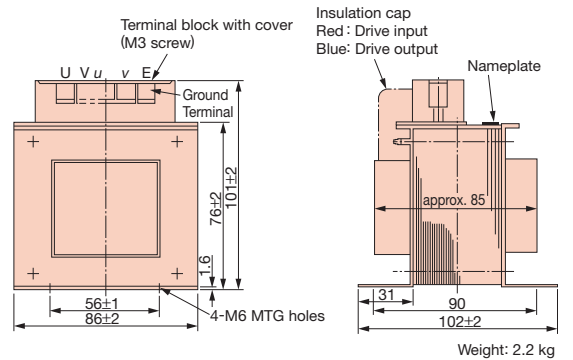



● Application Notes

Selection

■ Installing a Reactor

An AC or DC reactor can be used for the following:

- to suppress harmonic current.
- to smooth peak current that results from capacitor switching.
- when the power supply is above 600 kVA.
- Use an AC reactor when also connecting a thyristor converter to the same power supply system, regardless of the conditions of the power supply.

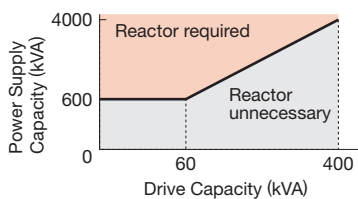

■ Drive Capacity

Make sure that the motor's rated current is less than the drive's output current. When running a specialized motor or more than one motor in parallel from a single drive, the capacity of the drive should be larger than 1.1 times of the total motor rated current.

■ Starting Torque

The overload rating for the drive determines the starting and accelerating characteristics of the motor. Expect lower torque than when running from line power. To get more starting torque, use a larger drive or increase both the motor and drive capacity.

■ Emergency Stop

When the drive faults out, a protective circuit is activated and drive output is shut off. This, however, does not stop the motor immediately. Some type of mechanical brake may be needed if it is necessary to halt the motor faster than the Fast Stop function is able to.

■ Options

She B1, B2, -, +1, and +2 terminals are used to connect optional devices. Connect only V1000-compatible devices.

■ Repetitive Starting/Stopping

Cranes (Hoists), elevators, punching presses, and other such applications with frequent starts and stops often exceed 150% of their rated current values. Heat stress generated from repetitive high current can shorten the lifespan of the IGBTs. The expected lifespan for the IGBTs is about 8 million start and stop cycles with a 4 kHz carrier frequency and a 150% peak current.

Yaskawa recommends lowering the carrier frequency, particularly when audible noise is not a concern. The user can also choose to reduce the load, increase the acceleration and deceleration times, or switch to a larger drive. This will help keep peak current levels under 150%. Be sure to check the peak current levels when starting and stopping repeatedly during the initial test run, and make adjustments accordingly.

For crane-type applications taking the inching function in which the motor is quickly started and stopped, Yaskawa recommends the following to ensure motor torque levels and lower the drive:

- Select a large enough drive so that peak current levels remain below 150%.
- The drive should be one frame size larger than the motor.

Installation

■ Enclosure Panels

Keep the drive in a clean environment by either selecting an area free of airborne dust, lint, oil mist, corrosive gas, and flammable gas, or install the drive in an enclosure panel. Leave the required space between the drives to provide for cooling, and take steps to ensure that the ambient temperature remains within allowable limits. Keep flammable materials away from the drive. If the drive must be used in an area where it is subjected to oil mist and excessive vibration, protective designs are available. Contact Yaskawa for details.

■ Installation Direction

The drive should be installed upright as specified in the manual.

■ Installation of Bypass Circuit

If the fuse blows or the circuit breaker (MCCB) trips, check the cable wiring and selection of peripheral devices and identify the cause. If the cause cannot be identified, do not turn ON the power supply or operate the device. Contact your Yaskawa representative.

If a drive fails and the motor will be directly driven using a commercial power supply, install the bypass circuit shown in the diagram below. If this bypass circuit is not installed, remove the drive and then connect the motor to a commercial power supply. (In other words, after disconnecting the cables connected to the main circuit terminals, such as main circuit power supply input terminals R/L1, S/L2, and T/L3 and drive output terminals U/T1, V/T2, and W/T3, connect the motor to a commercial power supply.)

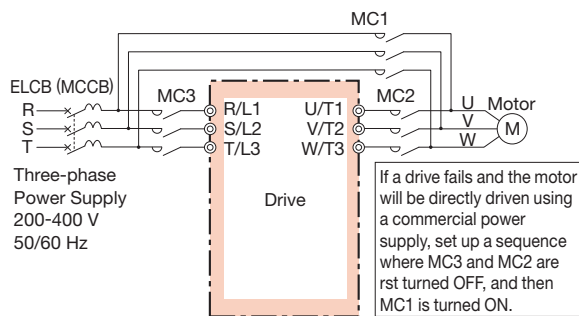

Settings

- If using Open Loop Vector Control designed for permanent magnet motors, make sure that the proper motor code has been set to parameter E5-01 before performing a trial run.
- Upper Limits

Because the drive is capable of running the motor at up to 400 Hz, be sure to set the upper limit for the frequency to control the maximum speed. The default setting for the maximum output frequency is 60 Hz.
- DC Injection Braking

Motor overheat can result if there is too much current used during DC Injection Braking, or if the time for DC Injection Braking is too long.
- Acceleration/Deceleration Times

Acceleration and deceleration times are affected by how much torque the motor generates, the load torque, and the inertia moment ($GD^2/4$). Set a longer accel/decel time when Stall Prevention is enabled. The accel/decel times are lengthened for as long as the Stall Prevention function is operating. For faster acceleration and deceleration, increase the capacity of the drive.

Compliance with Harmonic Suppression Guidelines

V1000 conforms to strict guidelines in Japan covering harmonic suppression for power conversion devices. Defined in JEM-TR201 and JEM-TR226 and published by the Japan Electrical Manufacturers' Association, these guidelines define the amount of harmonic current output acceptable for new installation. Contact your YASKAWA representative.

General Handling

■ Wiring Check

Never short the drive output terminals or apply voltage to output terminals (U/T1, V/T2, W/T3), as this can cause serious damage to the drive. Doing so will destroy the drive. Be sure to perform a final check of all sequence wiring and other connections before turning the power on. Make sure there are no short circuits on the control terminals (+V, AC, etc.), as this could damage the drive.

■ Magnetic Contactor Installation

Avoid switching a magnetic contactor on the power supply side more frequently than once every 30 minutes. Frequent switching can cause damage to the drive.

■ Inspection and Maintenance

After shutting off the drive, make sure the CHARGE light has gone out completely before performing any inspection or maintenance. Residual voltage in drive capacitors can cause serious electric shock.

The heatsink can become quite hot during operation, and proper precautions should be taken to prevent burns. When replacing the cooling fan, shut off the power and wait at least 15 minutes to be sure that the heatsink has cooled down.

■ Transporting the Drive

Never steam clean the drive.

During transport, keep the drive from coming into contact with salts, fluorine, bromine and other such harmful chemicals.



● Peripheral Devices

■ Installing a Ground Fault Interrupter or an MCCB

Install an MCCB or a ground fault interrupter recommended by Yaskawa to the power supply side of the drive to protect internal circuitry. The type of MCCB needed depends on the power supply power factor (power supply voltage, output frequency, load characteristics, etc.). Sometimes a fairly large MCCB may be required due to the effects of harmonic current on operating characteristics. Those using a ground fault interrupter other than those recommended in this catalog, use one fitted for harmonic suppression measures (one designed specifically for drives). The rated current of the ground fault interrupter must be 200 mA or higher per drive unit. Select an MCCB with a rated capacity greater than the short-circuit current for the power supply. For a fairly large power supply transformer, a fuse can be added to the ground fault interrupter or MCCB in order to handle the short-circuit current level.

■ Magnetic Contactor for Input Power

Use a magnetic contactor (MC) to ensure that power to the drive can be completely shut off when necessary.

The MC should be wired so that it opens when a fault output terminal is tripped.

Even though an MC is designed to switch following a momentary power loss, frequent MC use can damage other components. Avoid switching the MC more than once every 30 minutes. The MC will not be activated after a momentary power loss if using the operator keypad to run the drive. This is because the drive is unable to restart automatically when set for LOCAL. Although the drive can be stopped by using an MC installed on the power supply side, the drive cannot stop the motor in a controlled fashion, and it will simply coast to stop. If a braking resistor or dynamic braking unit has been installed, be absolutely sure to set up a sequence that opens the MC with a thermal protector switch connected to the braking resistor device.

■ Magnetic Contactor for Motor

As a general principle, the user should avoid opening and closing the magnetic contactor between the motor and the drive during run. Doing so can cause high peak currents and overcurrent faults. If magnetic contactors are used to bypass the drive by connecting the motor to the power supply directly, make sure to close the bypass only after the drive is stopped and fully disconnected from the motor. The Speed Search function can be used to start a coasting motor.

Use an MC with delayed release if momentary power loss is a concern.

■ Motor Thermal Over Load Relay Installation

Although the drive comes with built in electrothermal protection to prevent damage from overheat, a thermal relay should be connected between the drive and each motor if running several motors from the same drive. For a multipole motor or some other type of non-standard motor, Yaskawa recommends using an external thermal relay appropriate for the motor. Be sure to disable the motor protection selection parameter (L1-01 = 0), and set the thermal relay or thermal protection value to 1.1 times the motor rated current listed on the motor nameplate.

When a high carrier frequency and long motor cables are used, nuisance tripping of the thermal relay may occur due to increased leakage current. To avoid this, reduce the carrier frequency or increase the tripping level of the thermal overload relay.

■ Improving the Power Factor

Installing a DC or AC reactor to the input side of the drive can help improve the power factor.

Refrain from using a capacitor or surge absorber on the output side as a way of improving the power factor, because high-frequency contents on the output side can lead to damage from overheat. This can also lead to problems with overcurrent.

■ Radio Frequency Interference

Drive output contains high-frequency contents that can affect the performance of surrounding electronic instruments such as an AM radio. These problems can be prevented by installing a noise filter, as well as by using a properly grounded metal conduit to separate wiring between the drive and motor.

■ Wire Gauges and Wiring Distance

Motor torque can suffer as a result of voltage loss across a long cable running between the drive and motor, especially when there is low frequency output. Make sure that a large enough wire gauge is used.

The optional LCD operator requires a proprietary cable to connect to the drive. If an analog signal is used to operate the drive via the input terminals, make sure that the wire between the analog operator and the drive is no longer than 50 m, and that it is properly separated from the main circuit wiring. Use reinforced circuitry (main circuit and relay sequence circuitry) to prevent inductance from surrounding devices. To run the drive with a frequency potentiometer via the external terminals, use twisted shielded pair cables and ground the shield.

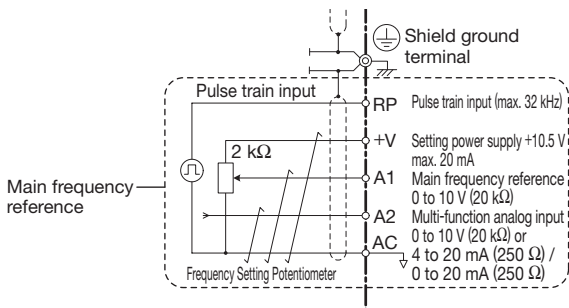

■ Counteracting Noise

Because V1000 is designed with PWM control, a low carrier frequency tends to create more motor flux noise than using a higher carrier frequency. Keep the following point in mind when considering how to reduce motor noise:

- Lowering the carrier frequency (C6-02) minimizes the effects of noise.
- A line noise filter can be effective in reducing the affects on AM radio frequencies and poor sensor performance. See "Options and Peripheral Devices" on page 28.
- Make sure the distance between signal and power lines is at least 10 cm (up to 30 cm is preferable), and use twisted pair cable to prevent induction noise form the drive power lines.

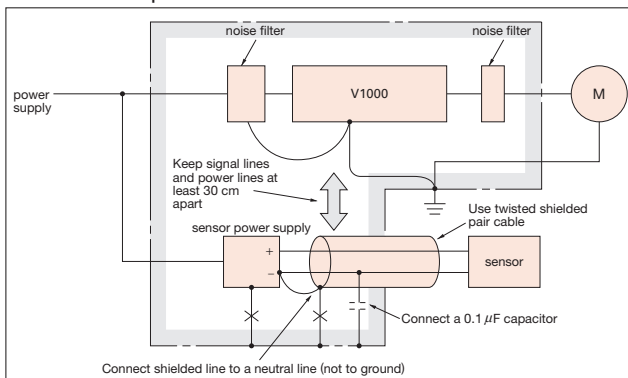

<Provided by JEMA>

■ Leakage Current

High-frequency leakage current passes through stray capacitance that exists between the power lines to the drive, ground, and the motor lines. Consider using the following peripheral devices to prevent problems with leakage current.

	Problem	Solution
Ground Leakage Current	MCCB is mistakenly triggered	<ul style="list-style-type: none"> • Lower the carrier frequency set to parameter C6-02. • Try using a component designed to minimize harmonic distortion for the MCCB such as the NV series by Mitsubishi.
Current Leakage Between Lines	Thermal relay connected to the external terminals is mistakenly triggered by harmonics in the leakage current	<ul style="list-style-type: none"> • Lower the carrier frequency set to parameter C6-02. • Use the drive's built-in thermal motor protection function.

The following table shows the guidelines for the set value of the carrier frequency relative to the wiring distance between the drive and the motor when using V/f control.

When Open Loop Vector Control or PM Open Loop Vector Control is used and the wiring distance is 50 m to 100 m, set the carrier frequency to 2 kHz.

Wiring Distance*	50 m or less	100 m or less	Greater than 100 m
C6-02: Carrier Frequency Selection	1 to Auto (15 kHz or less)	1, 2, 7 to Auto (5 kHz or less)	1, 7 to Auto (2 kHz or less)

*: When a single drive is used to run multiple motors, the length of the motor cable should be calculated as the total distance between the drive and each motor.

When the wiring distance exceeds 100 m, use the drive observing the following conditions.

- Select V/f control mode (A1-02=0)
- To start a coasting motor
 - a) Use the current detection type (b3-24=0) when using the speed search function, or
 - b) Set the DC injection braking time at start (b2-03=0.01 to 10.00 sec) to stop a coasting motor and restart it.

More than one synchronous motor cannot be connected to a single drive. The maximum wiring distance between the drive and the synchronous motor must be 100 m.



Notes on Motor Operation

Motor Bearing Life

In applications involving constant speed over long periods, such as fans, pumps, extruders, and textile machinery, the life of the motor bearing may be shortened. This is called bearing electrolytic corrosion.

The installation of a zero-phase reactor between the drive and motor, and the utilization of a motor with insulated bearings are effective countermeasures.

Details can be found in the technical documentation.

Contact your Yaskawa or nearest sales representative for more information.

Using a Standard Motor

Low Speed Range

There is a greater amount of loss when operating a motor using an drive than when running directly from line power. With a drive, the motor can become quite hot due to the poor ability to cool the motor at low speeds. The load torque should be reduced accordingly at low speeds. The figure above shows the allowable load characteristics for a Yaskawa standard motor. A motor designed specifically for operation with a drive should be used when 100% continuous torque is needed at low speeds.

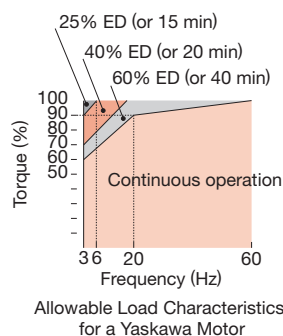

Insulation Tolerance

Consider voltage tolerance levels and insulation in applications with an input voltage of over 440 V or particularly long wiring distances.

High Speed Operation

Problems may occur with the motor bearings and dynamic balance in applications operating at over 60 Hz. Contact Yaskawa for consultation.

Torque Characteristics

Torque characteristics differ when operating directly from line power. The user should have a full understanding of the load torque characteristics for the application.

Vibration and Shock

V1000 lets the user choose between high carrier PWM control and low carrier PWM. Selecting high carrier PWM can help reduce motor oscillation. Keep the following points in mind when using high carrier PWM:

(1) Resonance

Take particular caution when using a variable speed drive for an application that is conventionally run from line power at a constant speed. Shock-absorbing rubber should be installed around the base of the motor and the Jump Frequency selection should be enabled to prevent resonance.

(2) Any imperfection on a rotating body increases vibration with speed

Caution should be taken when operating above the motor rated speed.

Audible Noise

Noise created during run varies by the carrier frequency setting. Using a high carrier frequency creates about as much noise as running from line power. Operating above the rated r/min (i.e., above 60 Hz), however, can create unpleasant motor noise.

Using a Synchronous Motor

- Please contact us for consultation when using a synchronous motor not already approved by Yaskawa.
- Even when the power has been shut off for a drive running a PM motor, voltage continues to be generated at the motor terminals while the motor coasts to stop. Take the precautions described below to prevent shock and injury:
 - Applications where the machine can still rotate even though the drive has fully stopped should have a low voltage manual load switch installed to the output side of the drive. (Yaskawa recommends the AICUT LB Series by AICHI Electric Works Co., Ltd.)
 - Do not apply to a load that could potentially rotate the motor faster than the maximum allowable r/min even when the drive has been shut off.
 - Wait at least one minute after opening the low voltage manual load switch on the output side before inspecting the drive or performing and maintenance.
 - Do not open a close the low voltage manual load switch while the motor is running, as this can damage the drive.
 - To close the low voltage manual load switch connected to a coasting motor, first turn on the power to the drive and make sure that the drive has stopped.
- Synchronous motors cannot be started directly from line power. Applications that requiring line power to start should use an induction motor with the drive.
- A single drive is not capable of running multiple synchronous motors at the same time. Use a standard induction motor for such setups.
- At start, a synchronous motor may rotate slightly in the opposite direction of the Run command depending on parameter settings and motor type.
- Uses derated torque of 50% less than starting torque. Set up the motor with the drive after verifying the starting torque, allowable load characteristics, impact load tolerance, and speed control range.
- Even with a braking resistor, braking torque is less than 125% when running between 20% to 100% speed, and falls to less than half the braking torque when running at less than 20% speed.
- There is no torque control available, and torque limits cannot be set. Consequently, synchronous motors are not appropriate for applications that operate at low speeds (less than 10% of the rated speed) or experience sudden changes in speed. Such applications are better suited for induction motors or servo drives.
- The allowable load inertia moment is 50 times less than the motor inertia moment. Contact Yaskawa concerning applications with a larger inertia moment.
- When using a holding brake, release the brake prior to starting the motor. Failure to set the proper timing can result in speed loss. Not for use with conveyor, transport, or hoist type applications.
- To restart a coasting motor rotating at over 120 Hz, use the Short Circuit Braking* function to first bring the motor to a stop. Short Circuit Braking requires a special braking resistor. Speed Search can be used to restart a coasting motor rotating slower than 120 Hz. If the motor cable is relatively long, however, the motor should instead be stopped using Short Circuit Braking and then restarted.
 - *: Short Circuit Braking creates a short-circuit in the motor windings to forcibly stop a coasting motor.



● Applications with Specialized Motors

■ Multi-pole Motor

Because the rated current will differ from a standard motor, be sure to check the maximum current when selecting a drive. Always stop the motor before switching between the number of motor poles. If a regenerative overvoltage fault occurs or if overcurrent protection is triggered, the motor will coast to stop.

■ Submersible Motor

Because motor rated current is greater than a standard motor, select the drive capacity accordingly. Be sure to use a large enough motor cable to avoid decreasing the maximum torque level on account of voltage drop caused by a long motor cable.

■ Explosion-proof Motor

Both the motor and drive need to be tested together to be certified as explosion-proof. The drive is not for explosion proof areas.

■ Geared Motor

Continuous operation specifications differ by the manufacturer of the lubricant. Due to potential problems of gear damage when operating at low speeds, be sure to select the proper lubricant. Consult with the manufacturer for applications that require speeds greater than the rated speed range of the motor or gear box.

■ Single-phase Motor

Variable speed drives are not designed for operating single phase motors. Using a capacitor to start the motor causes high-frequency current to flow into the capacitors, potentially causing damage. A split-phase start or a repulsion start can end up burning out the starter coils because the internal centrifugal switch is not activated. V1000 is for use only with 3-phase motors.

■ Uras Vibrator

Uras vibrator is a vibration motor that gets power from centrifugal force by rotating unbalanced weights on both ends of the shaft. Make the following considerations when selecting a drive for use with an Uras vibrator:

- (1) Uras vibrator should be used within the drive rated frequency
- (2) Use V/f Control
- (3) Increase the acceleration time five to fifteen times longer than would normally be used due to the high amount of load inertia of an Uras vibrator

Note: A drive with a different capacity must be selected if the acceleration time is less than 5 s.

- (4) Drive may have trouble starting due to undertorque that results from erratic torque (static friction torque at start)

■ Motor with Brake

Caution should be taken when using a drive to operate a motor with a built-in holding brake. If the brake is connected to the output side of the drive, it may not release at start due to low voltage levels. A separate power supply should be installed for the motor brake. Motors with a built-in brake tend to generate a fair amount of noise when running at low speeds.

Power Driven Machinery (decelerators, belts, chains, etc.)

Continuous operation at low speeds wears on the lubricating material used in gear box type systems to accelerate and decelerate power driven machinery. Caution should also be taken when operating at speeds above the rated machine speed due to noise and shortened performance life.



YASKAWA AC Drive Series

Name	Feature	Capacity Range (kW)		Outline
		0.1	1 10 100 300 630	
J1000	Compact V/f Control AC Drive	Three-Phase 200 V Class	0.1 5.5	<ul style="list-style-type: none"> Ultra-small body enables side-by-side installation. Compact design of enclosure panel Easy operation with the Potentiometer Option Unit The noise-suppressing Swing PWM system reduces harsh sound. The full-range fully-automatic torque boost function provides high torque output. (100%/1.5 Hz, 150%/3 Hz) The Stall Prevention function and the momentary power loss ride-thru ensure continuous operation, regardless of load/power supply fluctuations or momentary power loss. The Overexcitation braking function enables rapid braking, without using a braking resistor.
		Single-Phase 200 V Class	0.1 2.2	
		Three-Phase 400 V Class	0.2 5.5	
V1000	Compact Vector Control AC Drive	Three-Phase 200 V Class	0.1 18.5	<ul style="list-style-type: none"> Small body and high performance (Current vector control) For both induction motors and synchronous motors (IPMM/SPMM) High starting torque: 200%/0.5 Hz* Torque limit function * At Heavy Duty rating, for induction motors with 3.7 kW or lower Application-specific function selection for simplified optimum setup Easy maintenance using the detachable terminal block with the parameter backup function
		Single-Phase 200 V Class	0.1 3.7	
		Three-Phase 400 V Class	0.2 18.5	
A1000	Advanced Vector Control AC Drive	Three-Phase 200 V Class	0.4 110	<ul style="list-style-type: none"> For both induction motors and synchronous motors (IPMM/SPMM) High starting torque IPM motor without a motor encoder: 0 r/min 200% torque Application preset function selection for simplified optimum setup Easy maintenance using the detachable terminal block with the parameter backup function
		Three-Phase 400 V Class	0.4 630	
Varispeed G7	General-purpose Inverter With Advanced Vector Control Minimal Noise	Three-Phase 200 V Class	0.4 110	<ul style="list-style-type: none"> The 400 V class uses 3-level control for a more perfect output waveform. Open Loop Vector control ensures 150% or higher torque during operation at 0.3 Hz. Flux Vector Control provides a high torque of 150% at zero speed. Easy maintenance and inspection using the detachable control circuit terminals and the detachable cooling fan. Software for various applications (for crane, hoist, etc.) The Auto-Tuning function upgrades all types of general motors to be compatible with high-performance drives.
		Three-Phase 400 V Class	0.4 300	
U1000	Low Harmonics Regenerative Matrix Converter	Three-Phase 200 V Class	5.5 55*	<ul style="list-style-type: none"> Drastically reduced power supply harmonics and improved harmonics environment. Power regeneration function with even greater energy efficiency. All-in-one design accomplished reduced wiring and saving space. Motor drive state-of-the-art technology, induction motor and, of course, synchronous motor drive are also possible. Commercial power supply can be switched without peripheral phase detectors and contactors. The visual programming function DriveWorksEZ is installed as standard, easily customized, and can be freely used on a PC.
		Three-Phase 400 V Class	2.2 500*	
ECOiPM Drive	Compact and Energy Efficiency Drives	Three-Phase 200 V Class	0.4 15	<ul style="list-style-type: none"> Grade higher than IE3 efficiency class saves energy during operation. V1000 drives combined with compact ECOiPM motors make more compact and lighter drive systems. Less maintenance because bearing grease life is approx. three times longer compared to use with induction motors. Improved reliability with elimination of an encoder of precision device.
		Three-Phase 400 V Class	0.4 15	
V1000pico Drive	Super Compact and Environmentally Drives	Three-Phase 200 V Class	0.1 0.75	<ul style="list-style-type: none"> V1000 drives combined with super compact V1000pico motors make more compact and lighter drive systems. Applicable in locations subject to water jets or abrasive powder with its protective enclosure rated IP65 or higher. Improved reliability with elimination of an encoder of precision device. Use of V1000 drives, which can control not only induction motors but also synchronous motors, brings the uniformity of your stock.
Special Use L1000A	Elevator Applications	Three-Phase 200 V Class	1.5 110	<ul style="list-style-type: none"> Cutting-edge drive technology allows L1000A to run a newly installed gearless synchronous motor, or a refurbished geared induction motor. This minimizes equipment required for your application. Interfaces to match gearless, synchronous motors and every type of absolute encoder. Even without a load sensor, high-performance torque compensation and high-resolution absolute encoder eliminate rollback when the brake is released. Output interrupt Satisfies safety requirements and Ensures a reliable elevator system. Rescue Operation switches to backup battery or UPS in case of a power outage. All standard models are compliant with the Europe's RoHS directive.
		Three-Phase 400 V Class	1.5 110	

*: Units are displayed in kW. When selecting a model, make sure that the rated output current is higher than the motor rating current.



● Warranty Information

■ Warranty Period

The period is 12 months from the date the product is first used by the buyer, or 18 months from the date of shipment, whichever occurs first.

■ Post-Warranty Repair Period

The post-warranty repair period applies to products that are not in the standard warranty period.

During the post-warranty repair period, Yaskawa will repair or replace damaged parts for a fee.

There is a limit to the period during which Yaskawa will repair or replace damaged parts.

Contact Yaskawa or your nearest sales representative for more information.

■ Warranty Scope

Failure diagnosis

The primary failure diagnosis shall be performed by your company as a rule.

By your company's request, however, we or our service sector can execute the work for your company for pay.

In such a case, if the cause of the failure is in our side, the work is free.

Repair

When a failure occurred, repairs, replacement, and trip to the site for repairing the product shall be free of charge.

However, the following cases have to be paid.

- Cases of failure caused by inappropriate storing, handling, careless negligence, or system design errors performed by you or your customers.
- Cases of failure caused by a modification performed by your company without our approval.
- Cases of failure caused by using the product beyond the specification range.
- Cases of failure caused by force majeure such as natural disaster and fire.
- Cases in which the warranty period has expired.
- Cases of replacement of consumables and other parts with limited service life.
- Cases of product defects caused by packaging or fumigation processing.
- Cases of malfunction or errors caused by programs created by you using DriveWorksEZ.
- Other failures caused by reasons for which Yaskawa is not liable.

The services described above are available in Japan only. Please understand that failure diagnosis is not available outside of Japan. If overseas after-sales service is desired, consider registering for the optional overseas after-sales service contract.

Exception of Guaranteed Duty

Lost business opportunities and damage to your property, including your customers and other compensation for work, is not covered by the warranty regardless of warranty eligibility, except when caused by product failure of Yaskawa products.

■ Definition of Delivery

For standard products that are not set or adjusted for a specified application, Yaskawa considers the product delivered when it arrives at your company and Yaskawa is not responsible for on-site adjustments or test runs.



Global Service Network



Region	Service Area	Service Location	Service Agency	Telephone/Fax
North America	U.S.A.	Chicago (HQ) Los Angeles San Francisco New Jersey Boston Ohio North Carolina	① YASKAWA AMERICA INC.	Headquarters ☎ +1-847-887-7000 FAX +1-847-887-7370
	Mexico	Mexico City	② PILLAR MEXICANA. S.A. DE C.V.	☎ +52-555-660-5553 FAX +52-555-651-5573
South America	Brazil	São Paulo	③ YASKAWA ELÉTRICO DO BRASIL LTDA.	☎ +55-11-3585-1100 FAX +55-11-3585-1187
	Colombia	Bogota	④ VARIADORES LTD.A.	☎ +57-1-795-8250
Europe	Europe, South Africa	Frankfurt	⑤ YASKAWA EUROPE GmbH	☎ +49-6196-569-300 FAX +49-6196-569-398
Asia	Japan	Tokyo, offices nationwide	⑥ YASKAWA ELECTRIC CORPORATION (Manufacturing, sales)	☎ +81-3-5402-4502 FAX +81-3-5402-4580
			⑦ YASKAWA ELECTRIC ENGINEERING CORPORATION (After-sales service)	☎ +81-4-2931-1810 FAX +81-4-2931-1811
	South Korea	Seoul	⑧ YASKAWA ELECTRIC KOREA CORPORATION (Sales)	☎ +82-2-784-7844 FAX +82-2-784-8495
			⑨ YASKAWA ENGINEERING KOREA CORPORATION (After-sales service)	☎ +82-2-3775-0337 FAX +82-2-3775-0338
	China	Beijing, Guangzhou, Shanghai	⑩ YASKAWA ELECTRIC (CHINA) CO., LTD.	☎ +86-21-5385-2200 FAX +86-21-5385-3299
	Taiwan	Taipei	⑪ YASKAWA ELECTRIC TAIWAN CORPORATION	☎ +886-2-8913-1333 FAX +886-2-8913-1513
	Singapore	Singapore	⑫ YASKAWA ASIA PACIFIC PTE.LTD. (Sales)	☎ +65-6282-3003 FAX +65-6289-3003
			⑬ YASKAWA ASIA PACIFIC PTE. LTD. (After-sales service)	☎ +65-6282-1601 FAX +65-6282-3668
	Thailand	Bangkok	⑭ YASKAWA ELECTRIC (THAILAND) CO., LTD.	☎ +66-2-017-0099 FAX +66-2-017-0090
	Vietnam	Ho Chi Minh	⑮ YASKAWA ELECTRIC VIETNAM CO., LTD.	☎ +84-8-3822-8680 FAX +84-8-3822-8780
		Hanoi		☎ +84-4-3634-3953 FAX +84-4-3654-3954
	India	Bengaluru	⑯ YASKAWA INDIA PRIVATE LIMITED	☎ +91-80-4244-1900 FAX +91-80-4244-1901
Indonesia	Jakarta	⑰ PT. YASKAWA ELECTRIC INDONESIA	☎ +62-21-2982-6470 FAX +62-21-2982-6471	
Oceania	Australia New Zealand	Contact to service agency in Singapore (⑫ ⑬).		

V1000

DRIVE CENTER (INVERTER PLANT)

2-13-1, Nishimiyaichi, Yukuhashi, Fukuoka, 824-8511, Japan
Phone +81-930-25-2548 Fax +81-930-25-3431
<http://www.yaskawa.co.jp>

YASKAWA ELECTRIC CORPORATION

New Pier Takeshiba South Tower, 1-16-1, Kaigan, Minatoku, Tokyo, 105-6891, Japan
Phone +81-3-5402-4502 Fax +81-3-5402-4580
<http://www.yaskawa.co.jp>

YASKAWA AMERICA, INC.

2121, Norman Drive South, Waukegan, IL 60085, U.S.A.
Phone +1-800-YASKAWA (927-5292) or +1-847-887-7000 Fax +1-847-887-7310
<http://www.yaskawa.com>

YASKAWA ELÉTRICO DO BRASIL LTDA.

777, Avenida Piraporinha, Diadema, São Paulo, 09950-000, Brasil
Phone +55-11-3585-1100 Fax +55-11-3585-1187
<http://www.yaskawa.com.br>

YASKAWA EUROPE GmbH

Hauptstraße 185, 65760 Eschborn, Germany
Phone +49-6196-569-300 Fax +49-6196-569-398
<http://www.yaskawa.eu.com> E-mail: info@yaskawa.eu.com

YASKAWA ELECTRIC KOREA CORPORATION

35F, Three IFC, 10 Gukjegeumyung-ro, Yeongdeungpo-gu, Seoul, 07326, Korea
Phone +82-2-784-7844 Fax +82-2-784-8495
<http://www.yaskawa.co.kr>

YASKAWA ASIA PACIFIC PTE. LTD.

30A Kallang Place, #06-01 Singapore 339213
Phone +65-6282-3003 Fax +65-6289-3003
<http://www.yaskawa.com.sg>

YASKAWA ELECTRIC (THAILAND) CO., LTD.

59, 1st-5th Floor, Flourish Building, Soi Ratchadapisek 18, Ratchadapisek Road, Huaykwang, Bangkok 10310, Thailand
Phone +66-2-017-0099 Fax +66-2-017-0799
<http://www.yaskawa.co.th>

PT. YASKAWA ELECTRIC INDONESIA

Secure Building-Gedung B Lantai Dasar & Lantai 1 Jl. Raya Protokol Halim Perdanakusuma, Jakarta 13610, Indonesia
Phone +62-21-2982-6470 Fax +62-21-2982-6471
<http://www.yaskawa.co.id/>

YASKAWA ELETRIC VIETNAM CO., LTD HO CHI MINH OFFICE

Suite 1904A, 19th Floor Centec Tower, 72-74 Nguyen Thi Minh Khai Street, Ward 6, District 3, Ho Chi Minh City, Vietnam
Phone +84-8-3822-8680 Fax +84-8-3822-8780

YASKAWA ELETRIC VIETNAM CO., LTD HA NOI OFFICE

2nd Floor, Somerset Hoa Binh Hanoi, No. 106, Hoang Quoc Viet Street, Cau Giay District, Hanoi, Vietnam
Phone +84-4-3634-3953 Fax +84-4-3654-3954

YASKAWA ELECTRIC (CHINA) CO., LTD.

22F, Link Square 1, No.222, Hubin Road, Shanghai, 200021, China
Phone +86-21-5385-2200 Fax +86-21-5385-3299
<http://www.yaskawa.com.cn>

YASKAWA ELECTRIC (CHINA) CO., LTD. BEIJING OFFICE

Room 1011, Tower W3 Oriental Plaza, No.1 East Chang An Ave.,
Dong Cheng District, Beijing, 100738, China
Phone +86-10-8518-4086 Fax +86-10-8518-4082

YASKAWA ELECTRIC TAIWAN CORPORATION

12F, No. 207, Sec. 3, Beishin Rd., Shindian Dist., New Taipei City 23143, Taiwan
Phone: +886-2-8913-1333 Fax: +886-2-8913-1513 or +886-2-8913-1519
<http://www.yaskawa.com.tw>

YASKAWA INDIA PRIVATE LIMITED

#17/A, 2nd Main, Electronic City, Phase-I, Hosur Road, Bengaluru 560 100, India
Phone +91-80-4244-1900 Fax +91-80-4244-1901
<http://www.yaskawaindia.in>

Certified for
ISO9001 and
ISO14001



JQA-QMA14913



JQA-EM0202

YASKAWA

YASKAWA ELECTRIC CORPORATION

In the event that the end user of this product is to be the military and said product is to be employed in any weapons systems or the manufacture thereof, the export will fall under the relevant regulations as stipulated in the Foreign Exchange and Foreign Trade Regulations. Therefore, be sure to follow all procedures and submit all relevant documentation according to any and all rules, regulations and laws that may apply. Specifications are subject to change without notice for ongoing product modifications and improvements.

© 2007 YASKAWA ELECTRIC CORPORATION

LITERATURE NO. KAEP C710606 081 <8>-0

Published in Japan July 2019

V1-01-19-06